



# SPRINT 3000

Jogs, staples, and folds in one operation. Quick and easy set-up and adjustment. Variable speed produces booklets up to 100 pages (off-line).\* 2 stapling heads, 4 stapling positions. Uses 210-staple sticks. Mounted on heavy-duty casters. Optional interface for on-line use with the MBM FC 10.

**A SAFETY ACCESS COVER**  
The transparent safety access cover will not allow machine to operate when open.

**B POWERED CONVEYOR**  
A powered exit conveyor stacks booklets neatly and folds away compact storage.

**C OPTIONAL TRIMMER**  
An optional face trimmer trims booklets up to 100 pages.\*



## Specifications:

Sheet capacity	25*	Electrical requirements	115 V, 60 Hz
Paper size	5.5" x 8" to 12" x 18"	Dimensions (DxWxH)	23" x 46"** x 36"
Speed	1,500 set/hr*	Shipping weight	280 lbs.

\*May vary due to variations in paper and power supply.

\*\* (20" width with conveyor stored)

# SPRINT TRIMMER

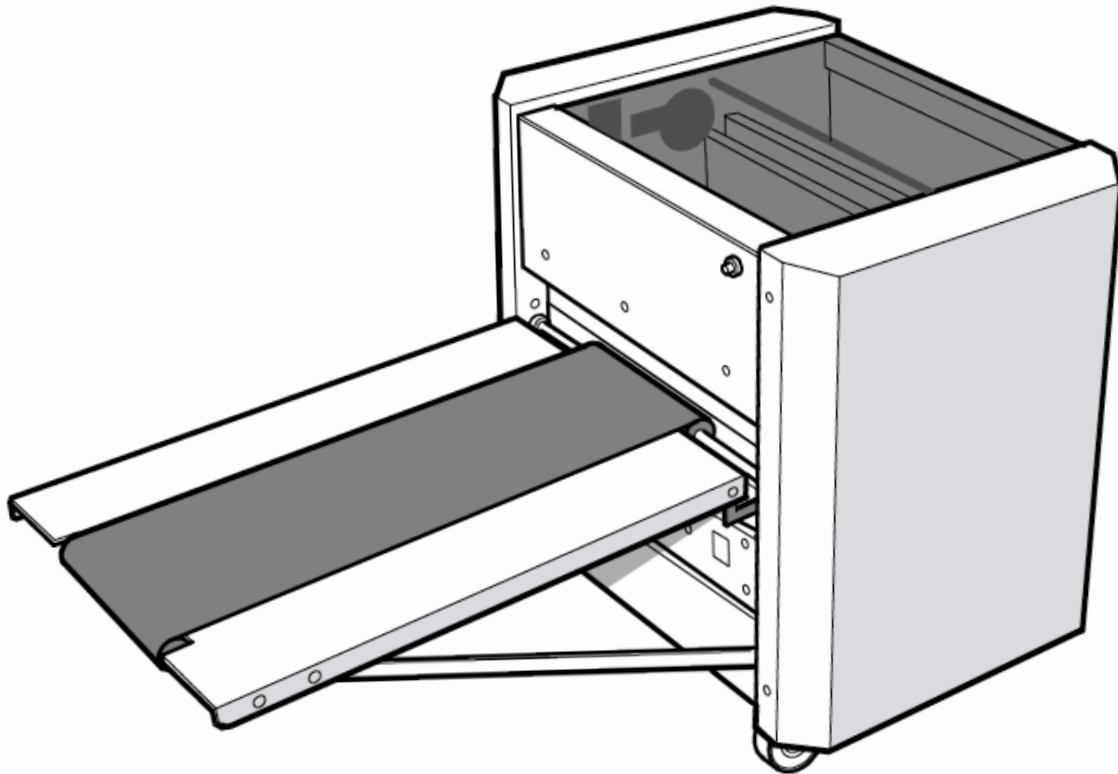

## **Trimmer Specifications:**

Max. Cutting Height:	50 sheets of 80 GSM bond
Book Sizes:	5.5" x 4.25" to 11" x 8.5"
Dimensions (DxWxH):	19.25" x 22.5" x 24.5"
Weight:	185.2 lbs.
Power:	110 V, 60 Hz, 180 Watts, Fuse: Mains inlet - 10 amp 110V. 24 Vdc power supply - 2.5 amp 110 V