

## 8 Template

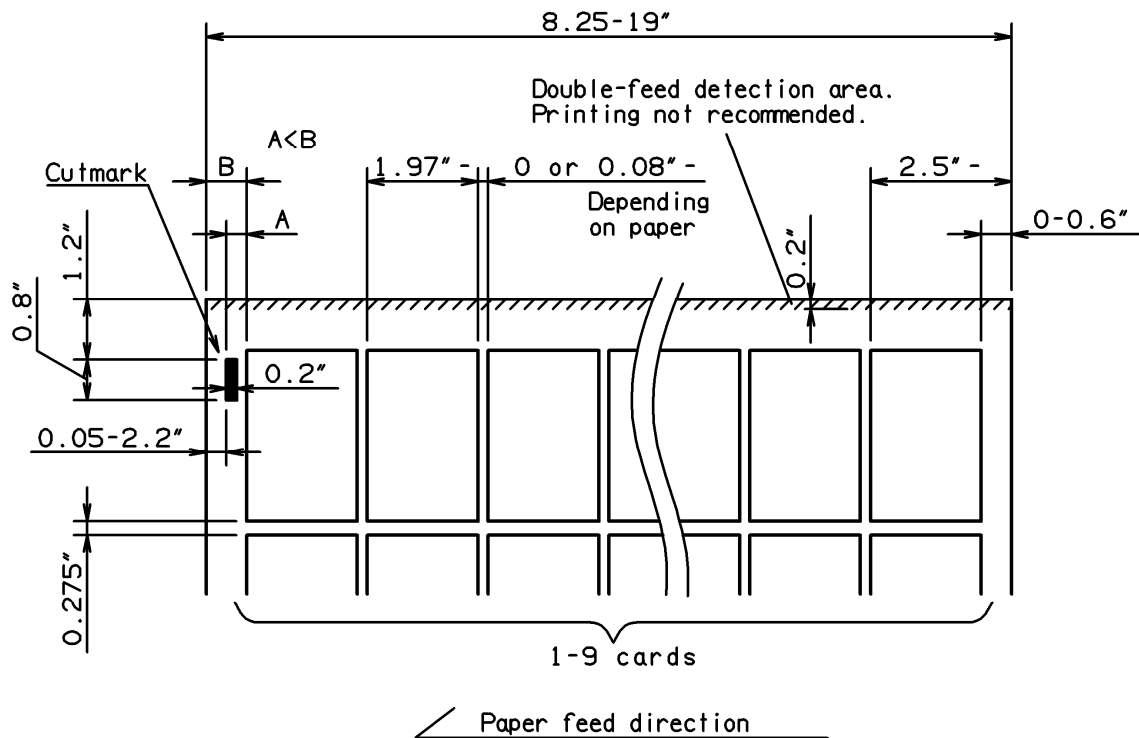

## 8.1 InstaSet bar UA Business Card 3.5"

**SUPER B** → Business Card 3.5"x2"

PRESET > SUPER B > BUSINESS CARD 2"

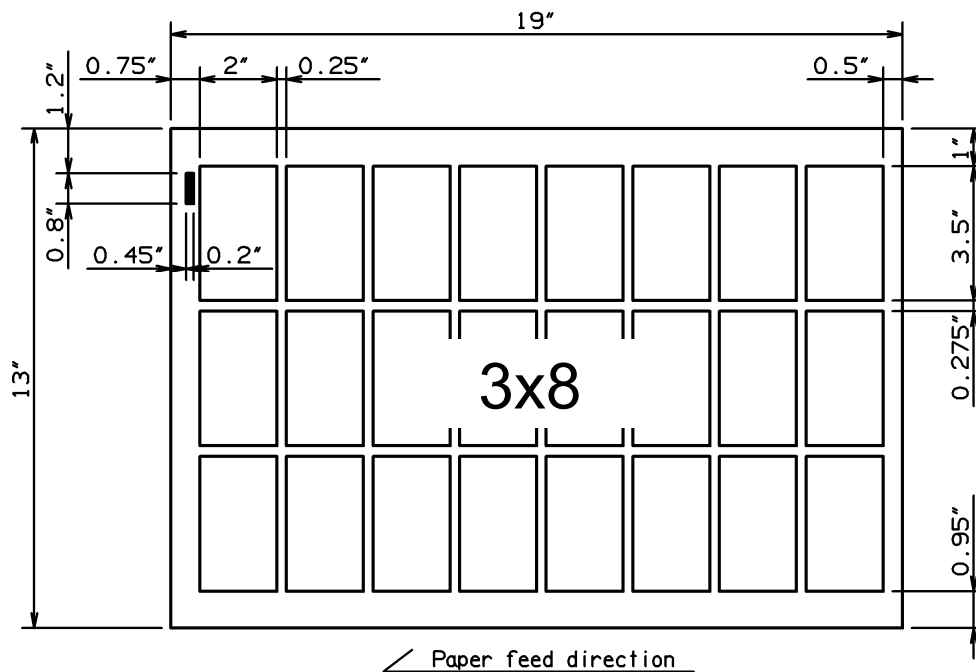

**ARCH B** → Business Card 3.5"x2"

PRESET > ARCH B > BUSINESS CARD 2"

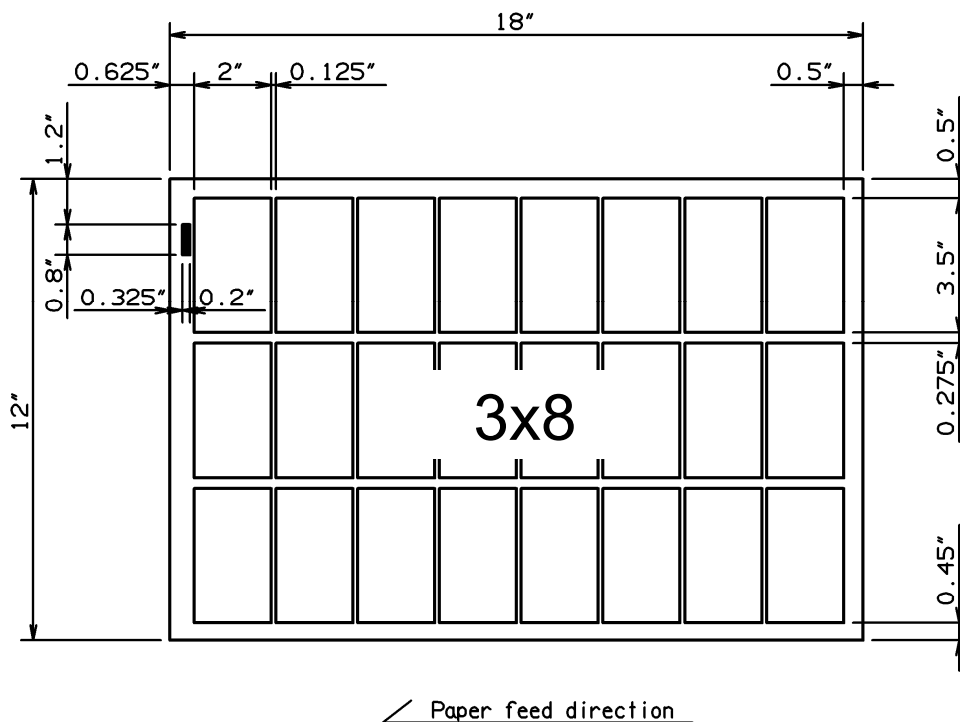

## 8.2 InstaSet bar UB Business Card 3.5"

**LEDGER (TABLOID) → Business Card 3.5"x2"**

PRESET > LEDGER > BUSINESS CARD 2"

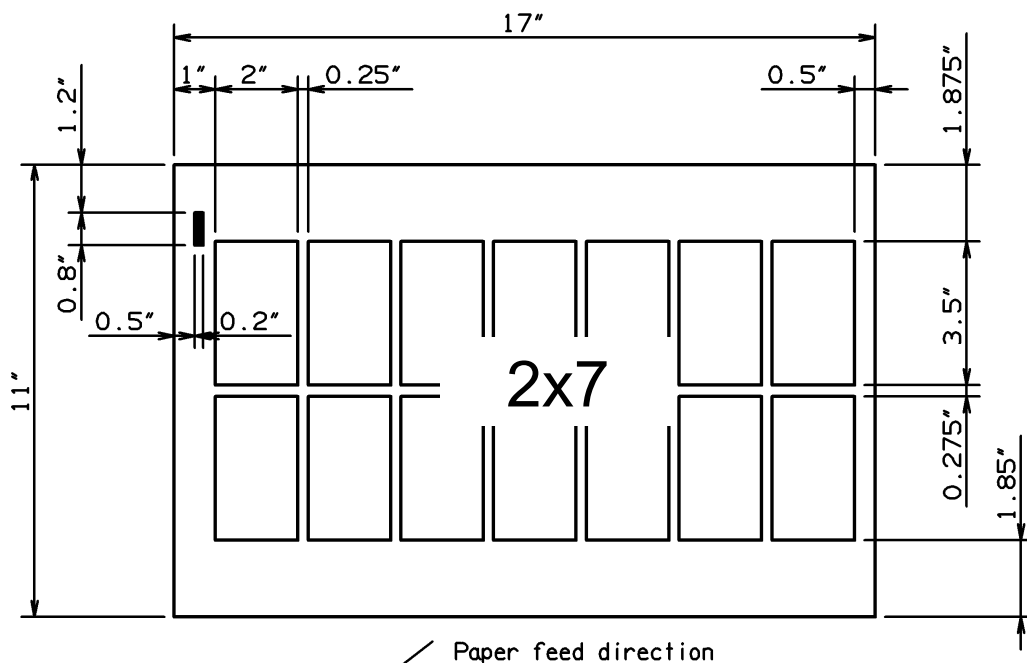

**LETTER(LEF) → Business Card 3.5"x2"**

PRESET > LETTER(LEF) > BUSINESS CARD 2"

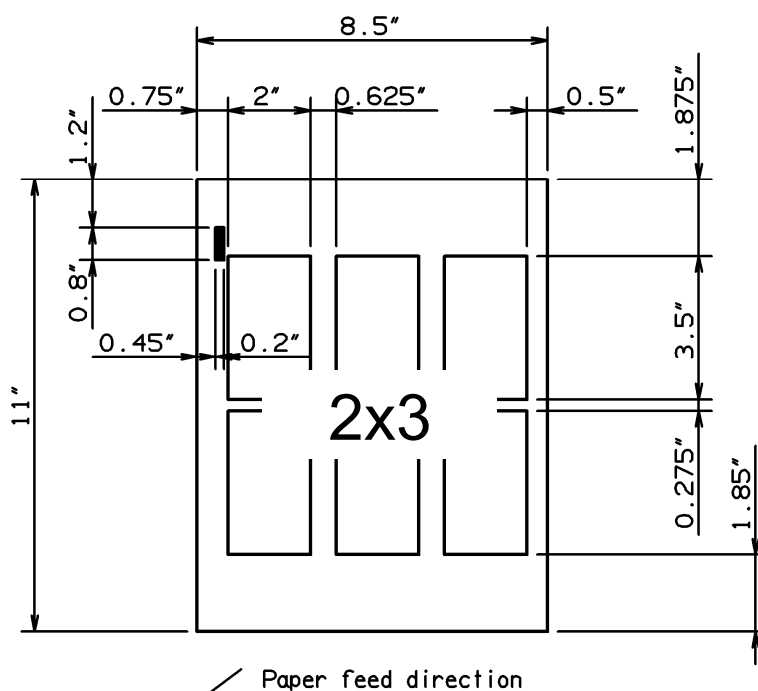

**8.3 InstaSet bar UC LEDGER / LETTER 11"**

**SUPER B → LEDGER 11"x17"**

PRESET > SUPER B > LEDGER

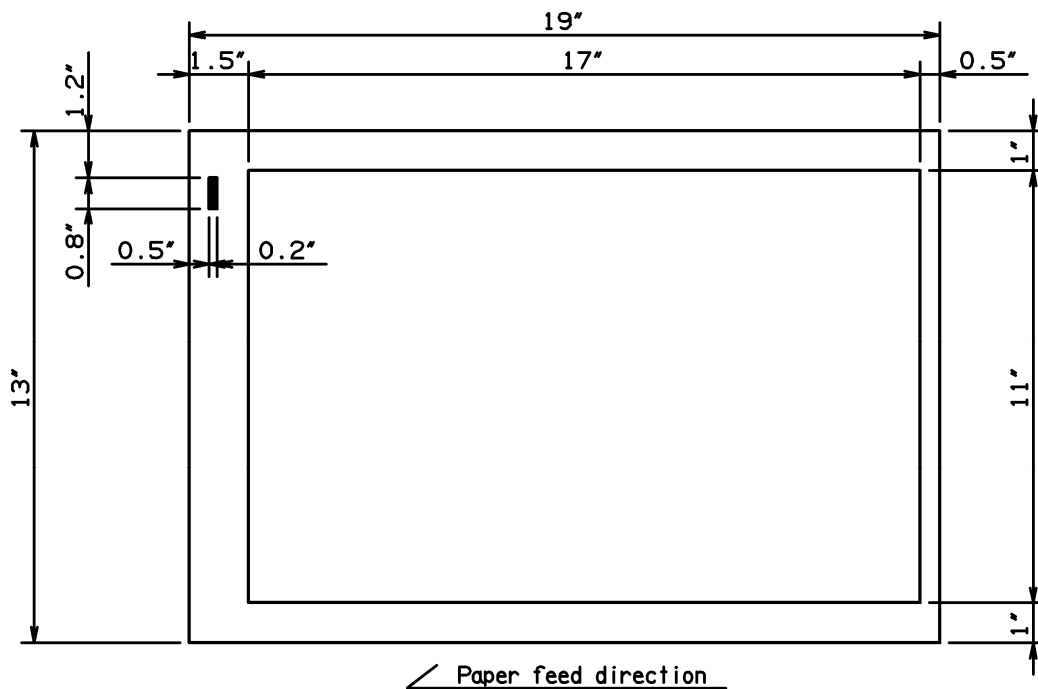

**ARCH B → LEDGER 11"x17"**

PRESET > ARCH B > LEDGER

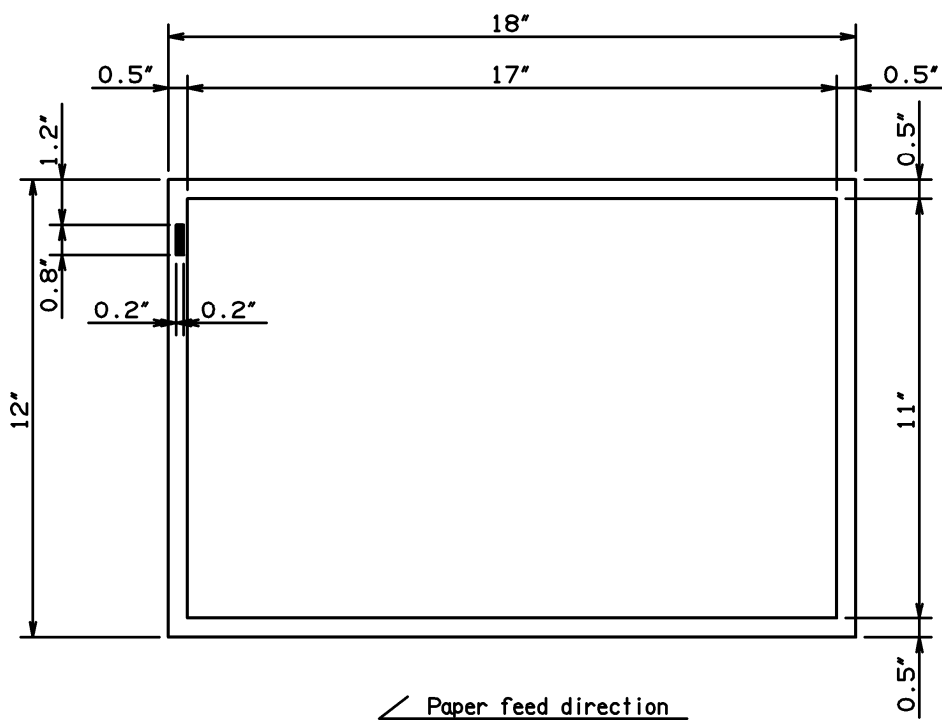

**SUPER B → LETTER 11"x8.5"**

PRESET > SUPER B > LETTER

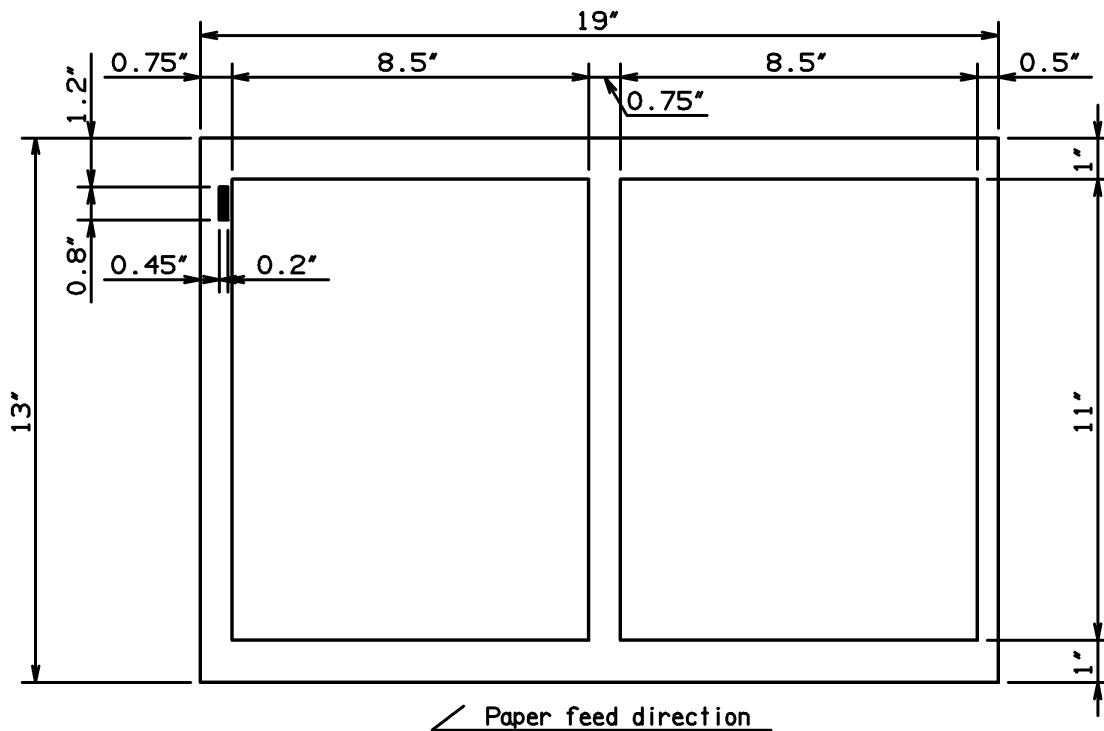

**ARCH B → LETTER 11"x8.5"**

PRESET > ARCH B > LEDGER

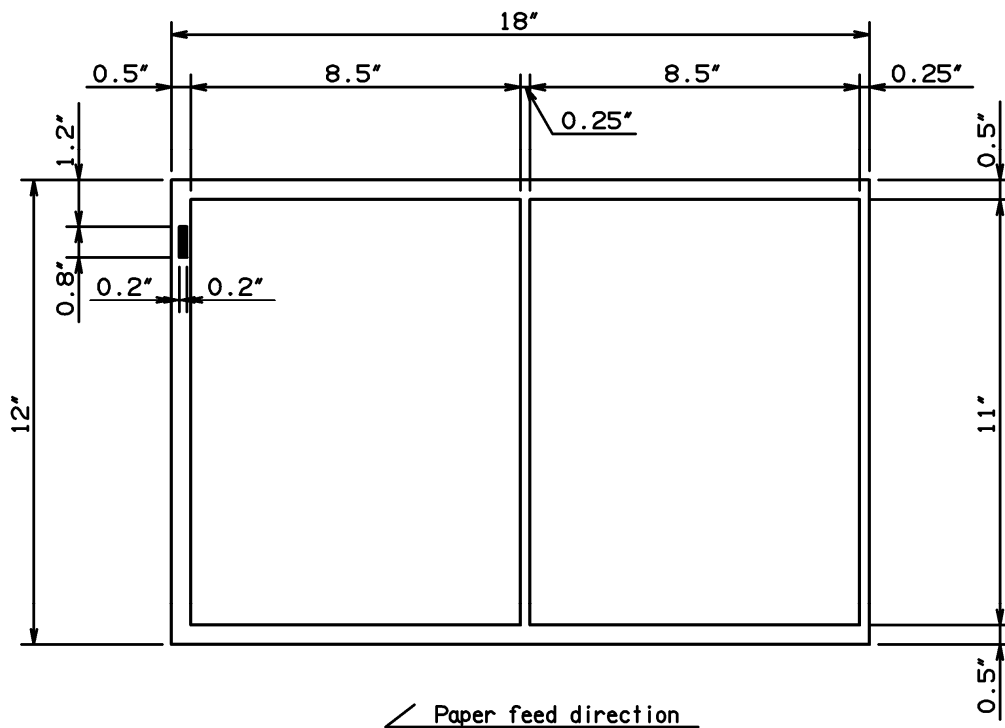

## 8.4 InstaSet bar UD POSTCARD 5"

**SUPER B → POSTCARD 5"x7"**

PRESET > SUPER B > POSTCARD

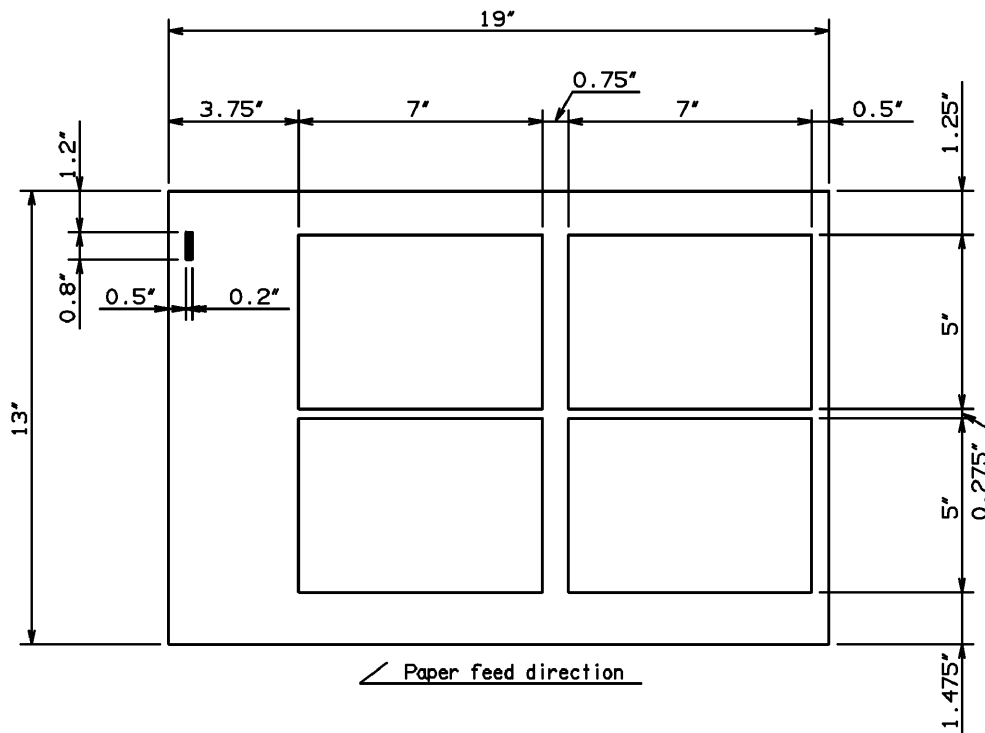

**ARCH B → POSTCARD 5"x7"**

PRESET > ARCH B > POSTCARD

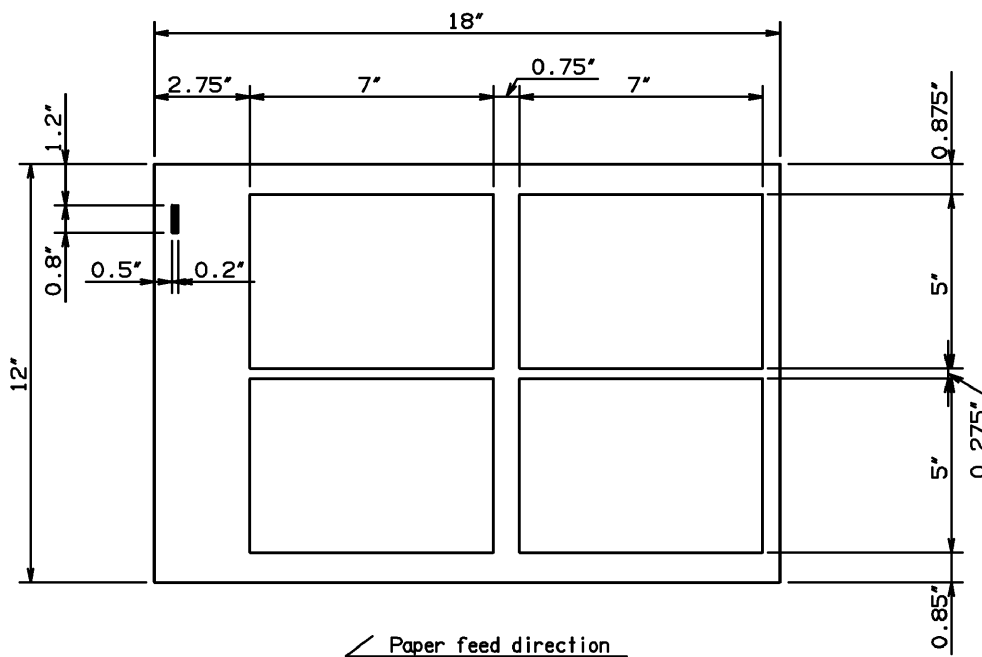

**LEDGER → POSTCARD 5"x7"**

PRESET > LEDGER > POSTCARD

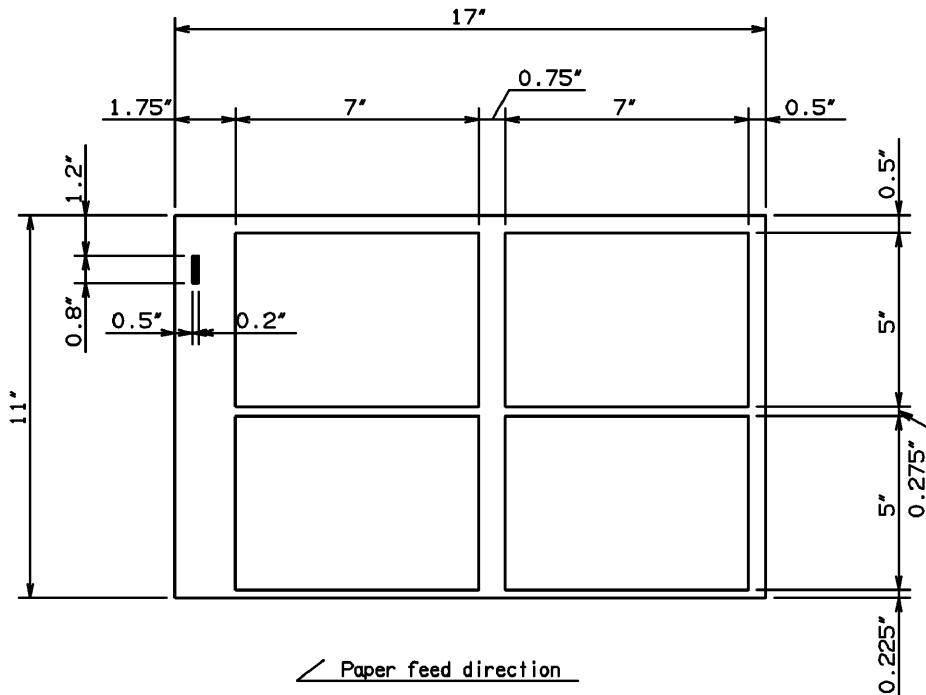

### 8.5 InstaSet bar UE POSTCARD 4"

**SUPER B** → Postcard 4"x6"

PRESET > SUPER B > POSTCARD

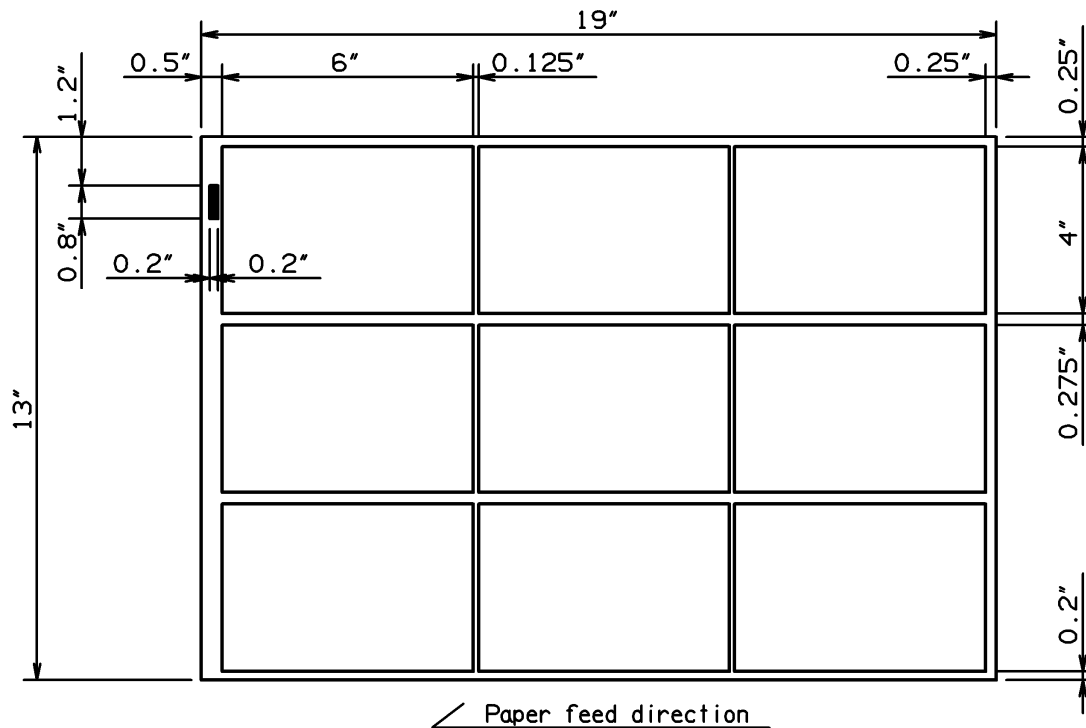

### 8.6 InstaSet bar UF POSTCARD 4"

**ARCH B** → Postcard 4"x6"

PRESET > ARCH B > POSTCARD

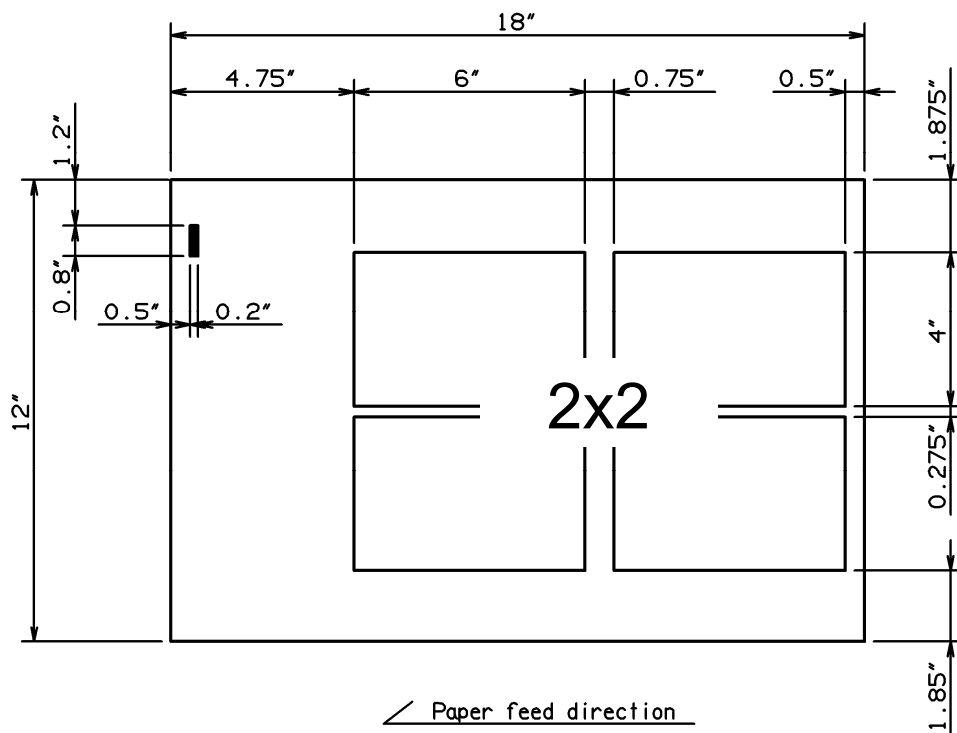



**8.7 InstaSet bar UG RACKCARD 3.75"**

**SUPER B → RACKCARD 3.75"x8.5"**

**PRESET > SUPER B > RACKCARD 3.75"**

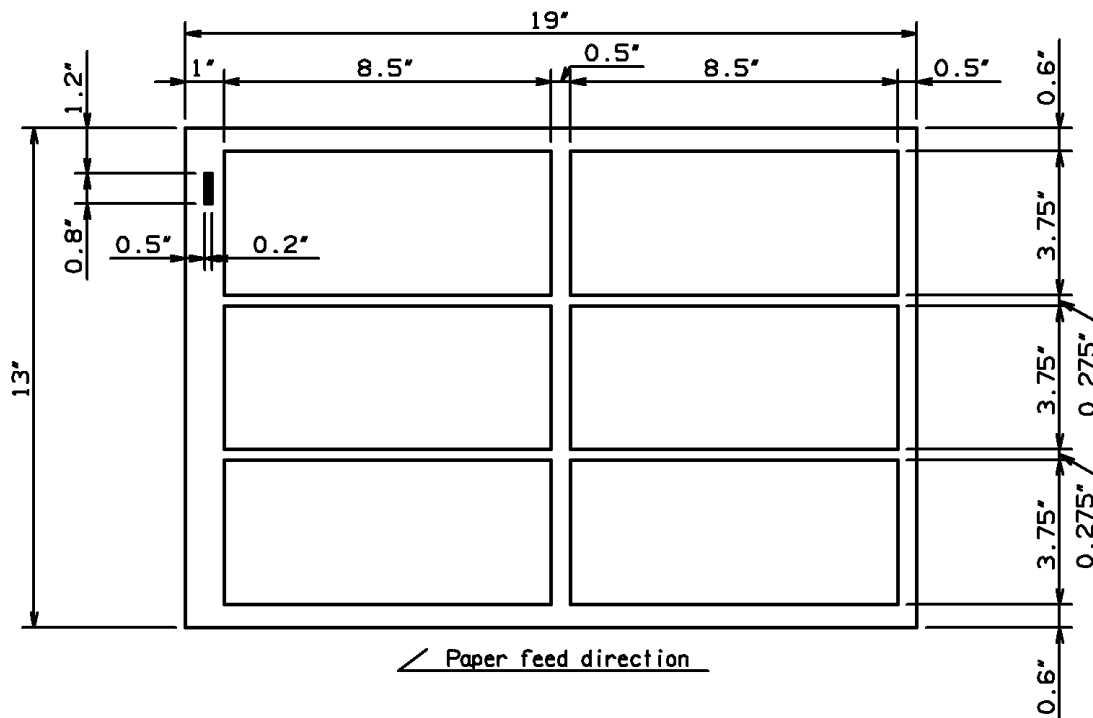

**8.8 InstaSet bar UH RACKCARD 8.5" / LEGAL8.5"**

**ARCH B → RACKCARD 8.5" x 3.75"**

PRESET > ARCH B > RACKCARD 8.5"

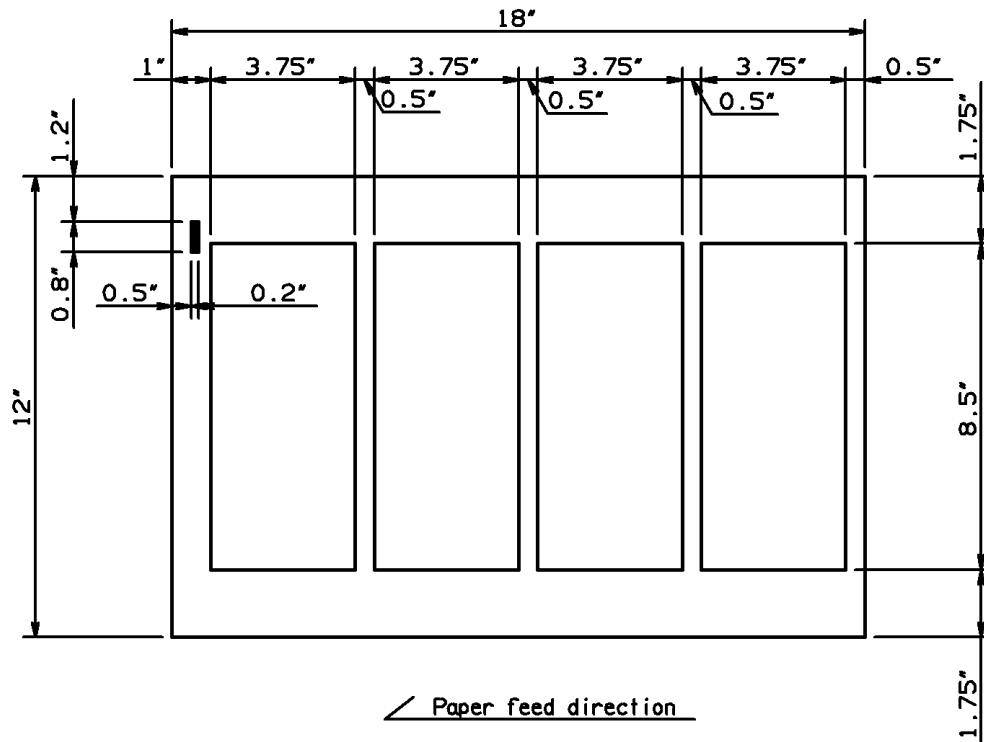

**LEDGER → 8.5" x 3.75"**

PRESET > LEDGER > RACKCARD 8.5"

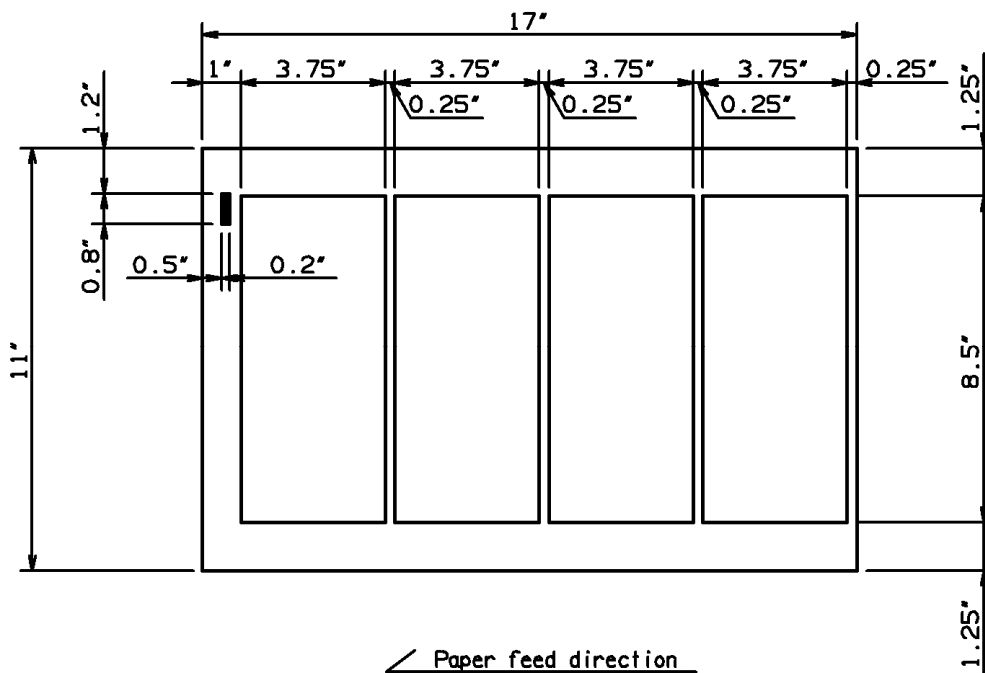

**ARCH B → LEGAL 8.5" x 14"**

PRESET > ARCH B > LEGAL

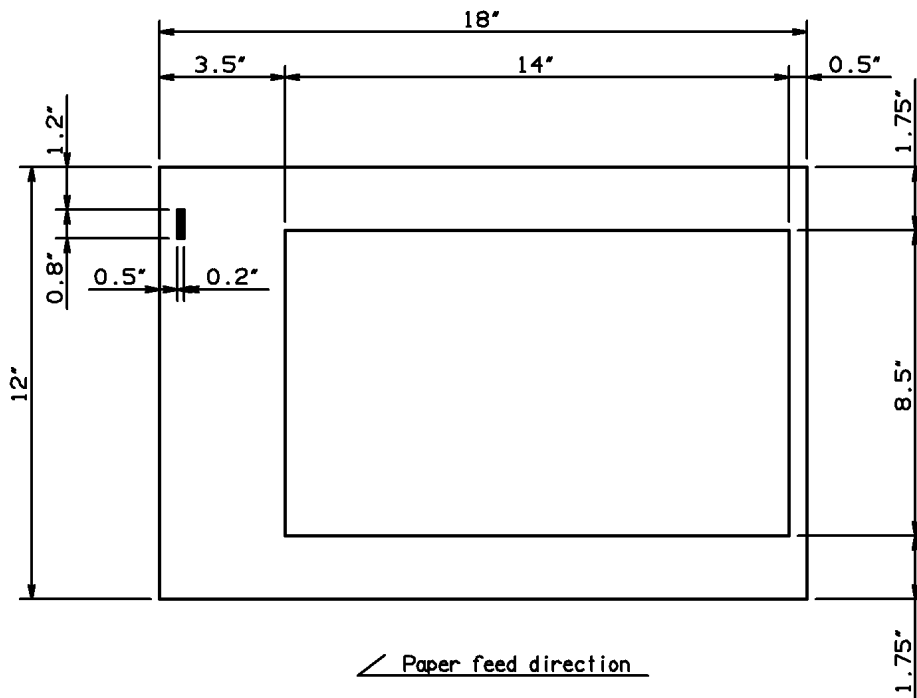

**LEDGER → LEGAL 8.5" x 14"**

PRESET > LEDGER > LEGAL

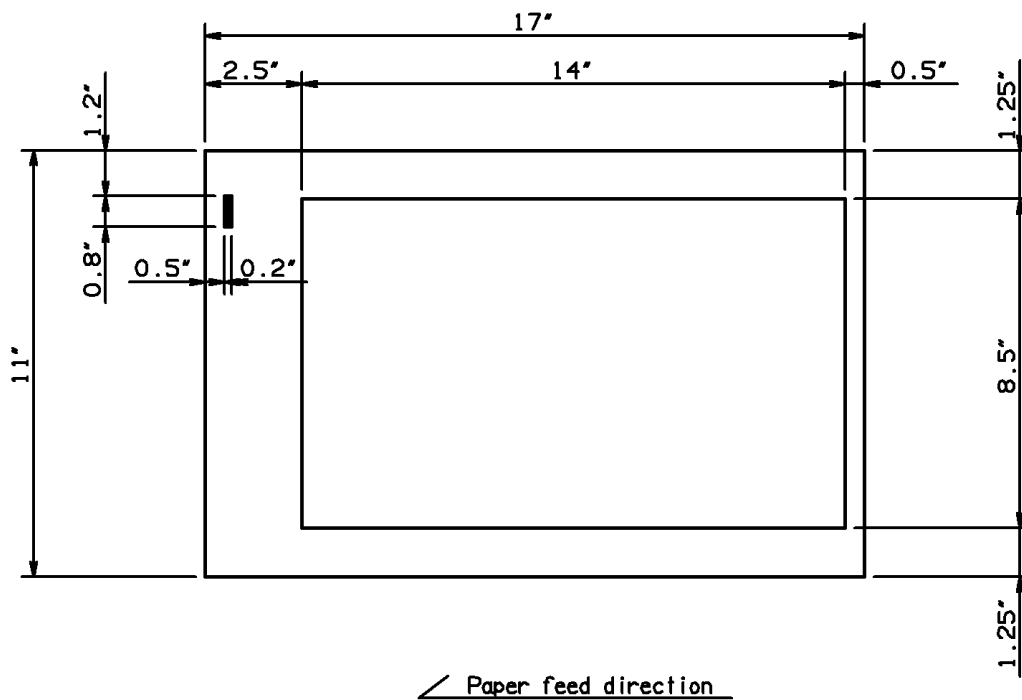

## 8.9 No bar required

**Note:** If the bar is not used, the risk of paper jams increases particularly with thin stocks.

**LEGAL 8.5" x 14" → LETTER 8.5" x 11"**

**PRESET** > **LEGAL** > **LETTER**

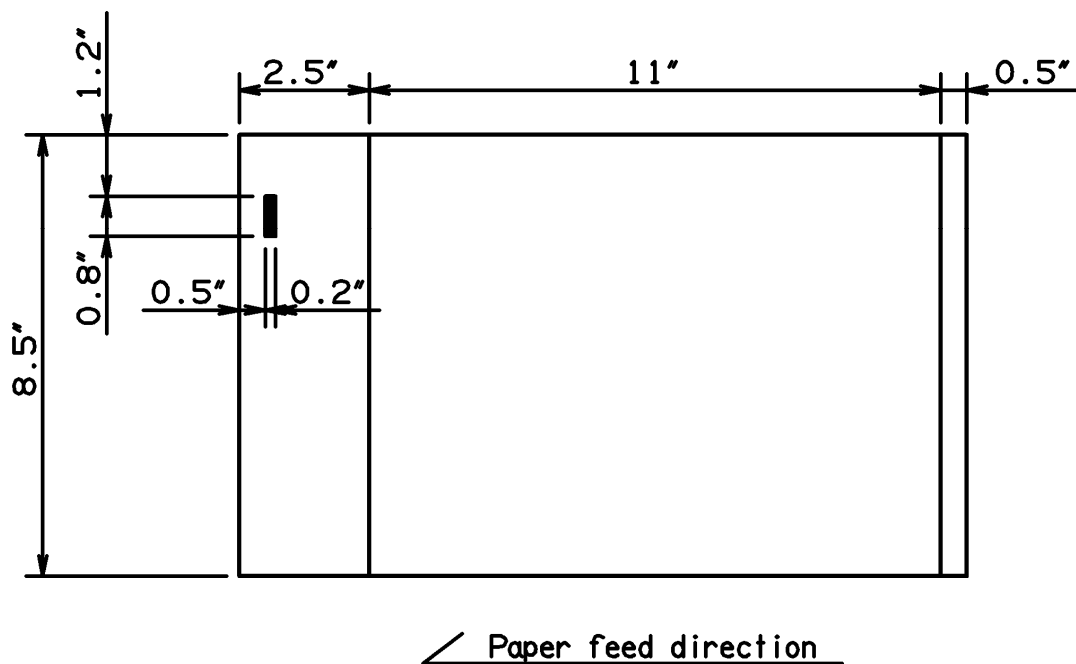

**ARCH B → DIV2, DIV3, DIV4**

**PRESET** > **ARCH B** > **DIV2** or **DIV3** or **DIV4**

**LEDGER → DIV2(LETTER), DIV3, DIV4**

**PRESET** > **LEDGER** > **DIV2** or **DIV3** or **DIV4**

**LEGAL → DIV2, DIV3, DIV4**

**PRESET** > **LEGAL** > **DIV2** or **DIV3** or **DIV4**

**LETTER(SEF) → DIV2, DIV3, DIV4**

**PRESET** > **LETTER(SEF)** > **DIV2** or **DIV3** or **DIV4**

## 8.10 BTO TEMPLATE

Maximum input paper size (Depth direction x feed direction)	13" x 19"
Minimum input paper size (Depth direction x feed direction)	8.25" x 8.25"
Minimum output size (Depth direction x feed direction)	3.5" x 2"
Paper weight	6 – 16pt.* (120-400g/m <sup>2</sup> )

