

OPERATION MANUAL

for

Scoring unit & Perforating unit

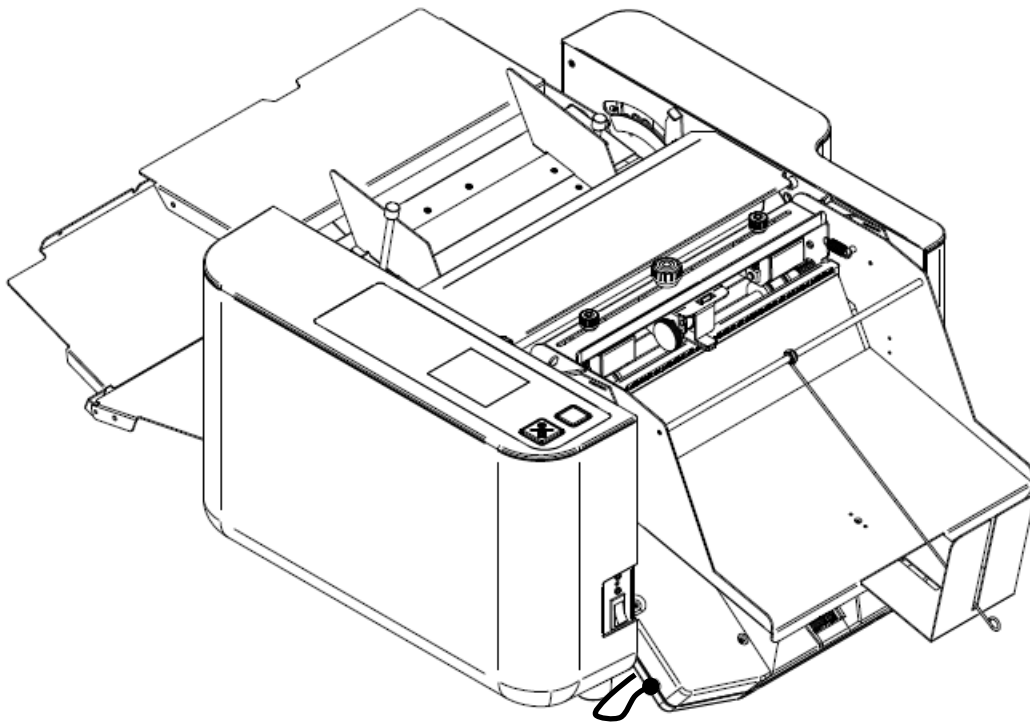

Read this operation manual carefully before use.
Keep this booklet handy for your reference anytime.



The Leader in Paper Handling Equipment

1-800-223-2508

www.mbmcorp.com

Sep,9,2016

Before use

Read this operation manual carefully before use.

Keep this booklet handy for your reference anytime.

Specifications are subject to change without notice for product improvement.

Always refer the original manual which came with the delivered unit.

Index

1. Names of Parts	3
2. Preparation before use.....	4
3. How to use	
1) Perforation Unit	
3.1 Setting Perforating Block	5
3.2 Method for changing operation mode.....	8
3.3 Trial Perforation.....	8
3.4 Fine Adjustment of Perforating Line	9
3.5 Perforation, continuous.....	10
3.6 Replacing Perforating Blade.....	11
How to use Thick-Paper Perforating Unit (Option).....	12
How to Replace the Separator with Thick-paper Separator	13
2) Scoring Unit	
3.7 Setting Scoring Block.....	14
3.8 Trial Scoring	15
3.9 Fine Adjustment of Scoring Line.....	15
3.10 Scoring, continuous	16
4. Adding Perforation Unit	17
5. Exchanging Perforation Unit to Scoring Unit.....	19
6. Replacing Transport Rubber Ring	20
7. Troubleshooting.....	21
8. Product Specifications	21

1. Names of Parts

Perforating Unit

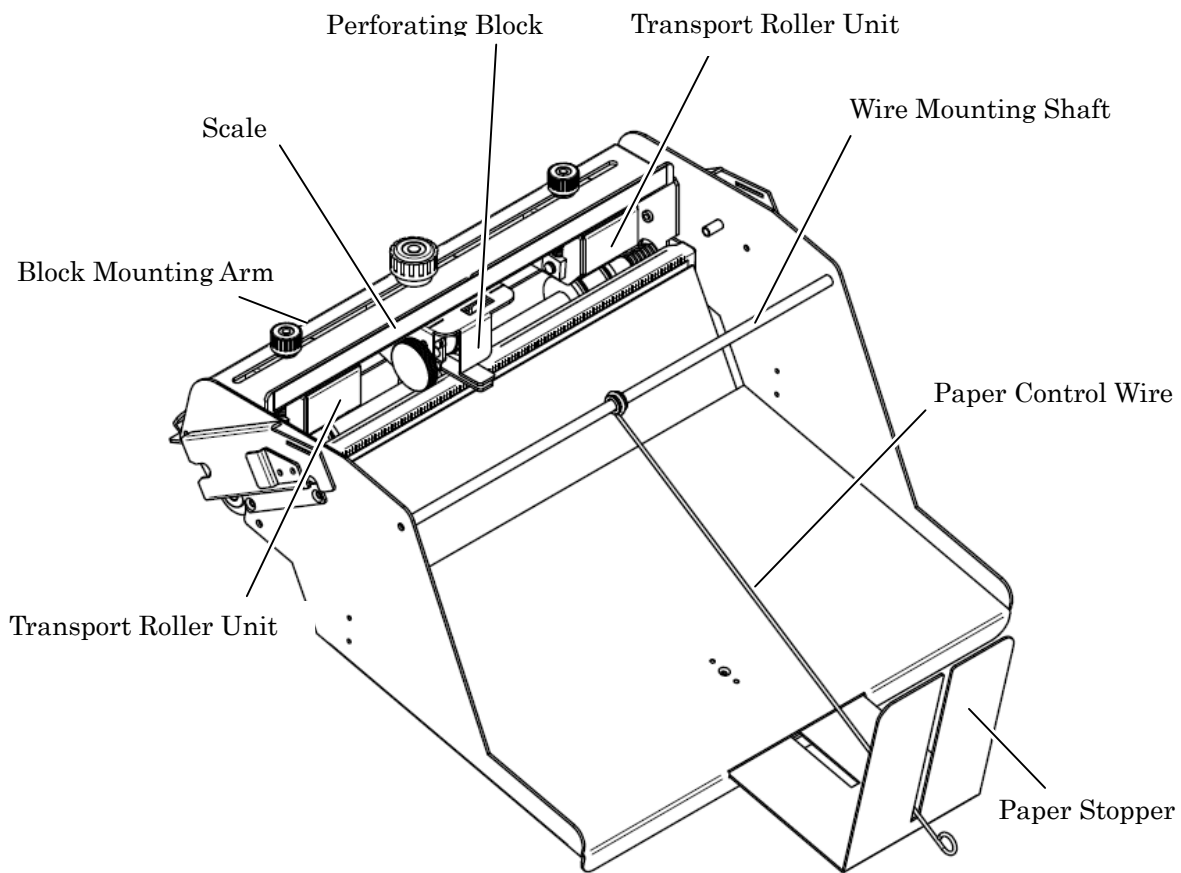

The paper processing part

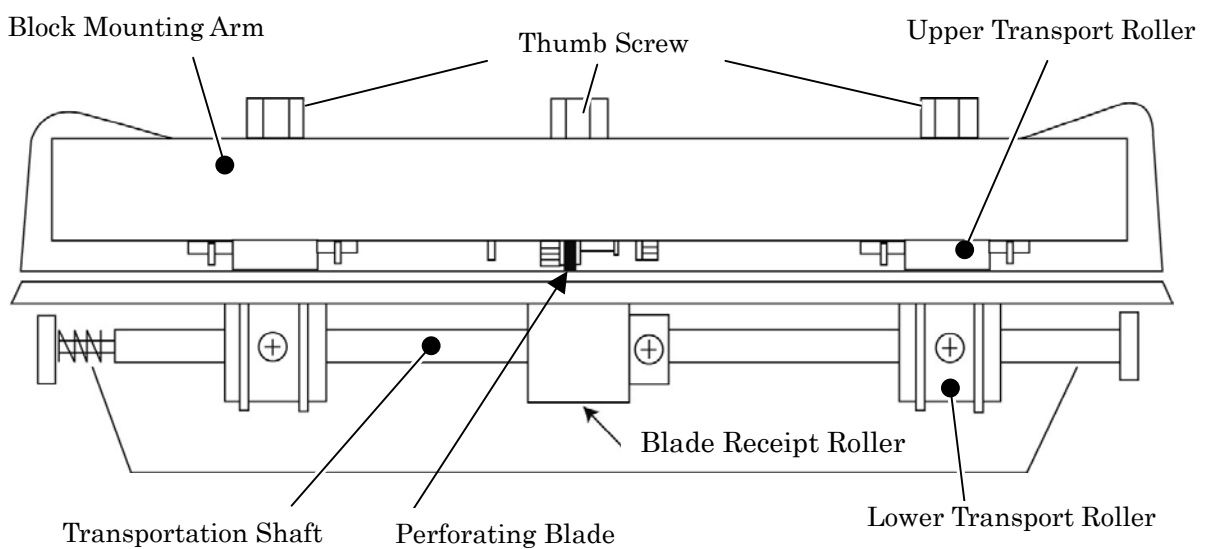

2. Preparation before use

- (1) Remove 1st Folding Table to the direction of arrow.
- (2) Remove the connector of 2nd Folding Table.

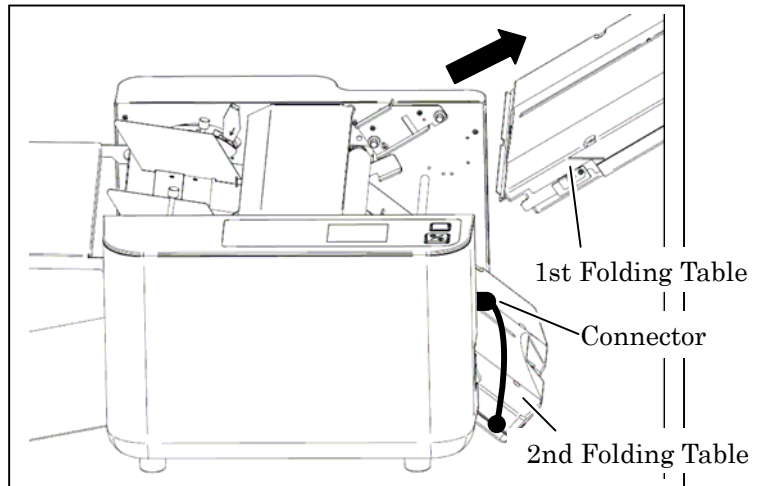

- (3) Install Perforating / Scoring Unit to the place where 1st Folding Table was mounted.

NOTE:

Insert the Connecting Plates of Perforator to the Guides of Folding machine.

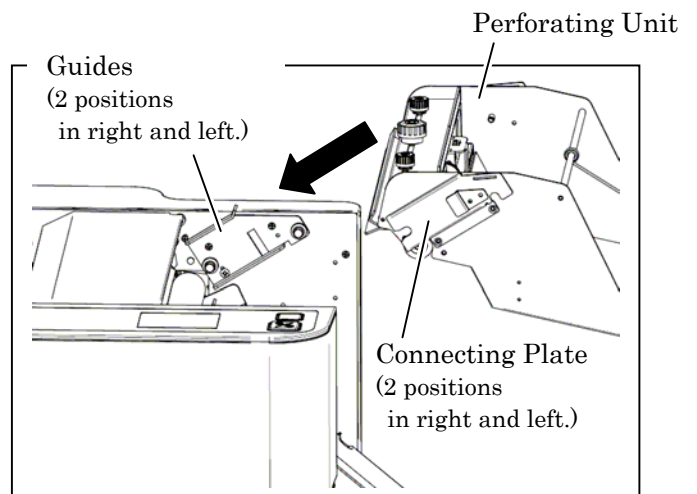

- (4) Set the Paper Control Wire onto the center of Wire Mounting Shaft and place the Wire Rubber Rings on the both sides of the wire.
- (5) Fix the Wire Mounting Shaft on the body of Perforating unit with screws.

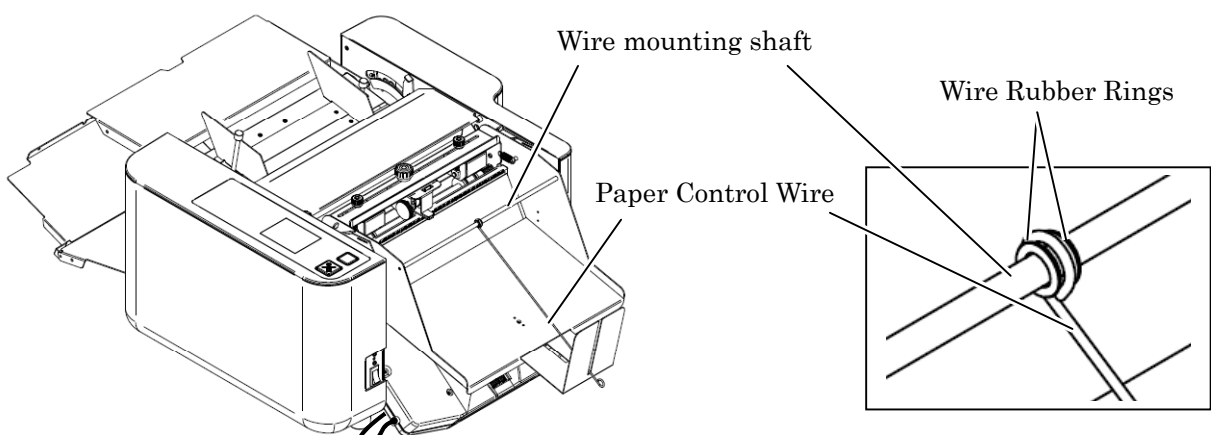

View after Perforating unit is mounted

3. How to use

1) Perforation Unit

3.1 Setting Perforating Block

- 1) Loose Thumb Screw and squeeze Release Levers by fingers to slide Perforating Block right or left. Refer guide scale.

NOTE:

Before setting Perforating Block, make sure to place Blade Position Reference at center position so that fine adjustment may be possible after the Block is installed.
Refer “3.4.1 Adjusting line location”

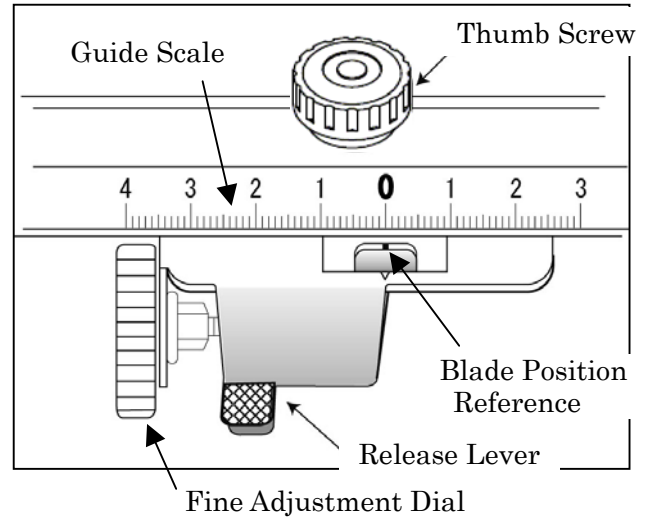

- (2) Fitting and fixing Blade Receipt Roller

- Loosen Roller Fixing Screw by Phillips Screw Driver and place Blade Receipt Roller fit to the Perforating Blade.
- Then fix Roller Fixing Screw.

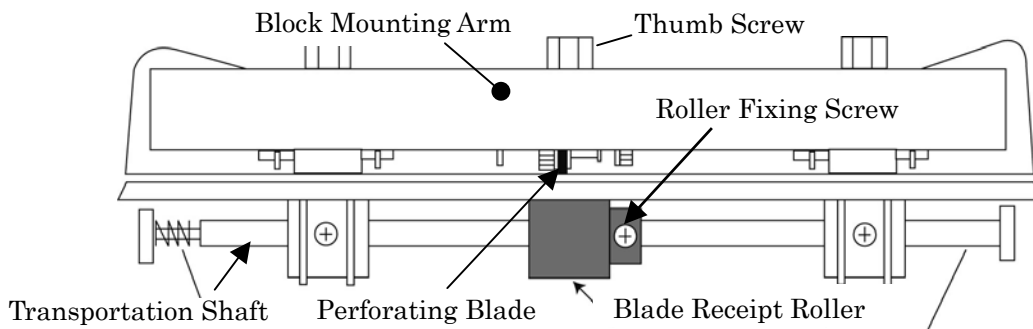

CAUTION:

While fixing Thumb Screw, press Thumb Screw towards Block Mounting Arm so that Perforating Block sets square to Block Mounting Arm. This helps the paper to be fed straight.

CAUTION:

Perforating Blade is designed always to be pressed against Blade Receipt Roller. Do not move the Roller without squeezing Release Levers. When Levers are squeezed, they give distance between Blade and Roller.

CAUTION:

Roller Fixing Screw must be fixed at the position where Transport Shaft has flat cut. Otherwise, the Blade Receipt Roller will not be fixed to the Shaft and the Roller may be damaged.

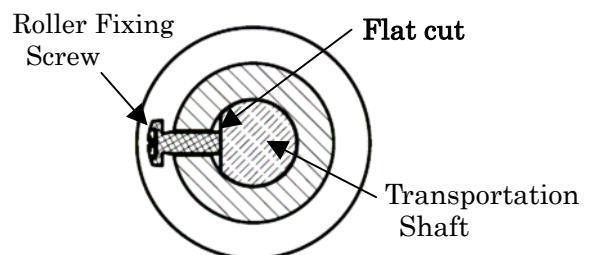

(3) Setting Paper Transport Rollers, Upper and Lower, at proper position

Place the Paper Transport Roller where they can grip paper positively.

Firstly, loosen Lower Philips Fixing Screws on both sides.

Slide and position them to the appropriate location and fix them.

Then, loosen Thumb Screws of Upper Transport Rollers on both sides.

Slide and position them so that Upper Transport Rollers ride on the Lower Transport Rubber Rings.

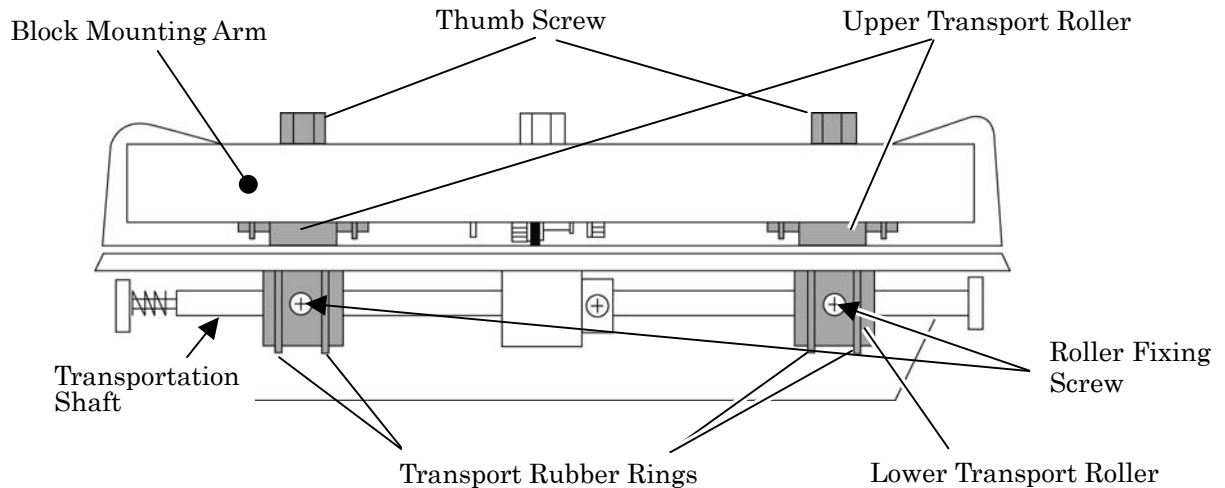

CAUTION:

Press Thumb Screw to Block Mounting Arm when fixing the Perforating Block. This helps the paper to be fed straightly.

CAUTION:

Depending location of perforating line, it may not always be possible to place Upper Transport Roller riding on the two Rubber Rings. In this case, we have to live with single Rubber Ring. However, as much as possible, try to use two Rubber Rings at both sides for stable paper feeding.

【Perforation Examples】

(1) Perforating at the center of a sheet

- Place Blade Position Reference to 0 (Zero) position of the scale.

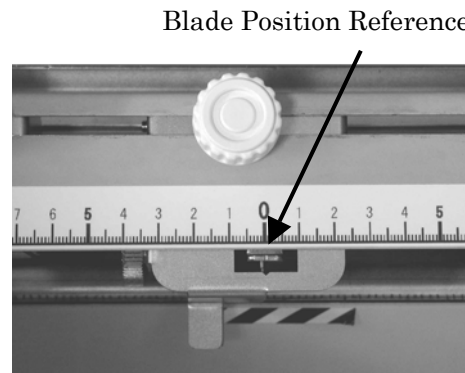
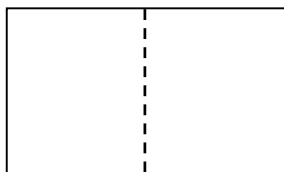

(2) Perforating two lines on a sheet by single perforation block.

- Place Blade Position Reference to adequate position and perforate.
- After first perforation done, reload the sheet to Paper Feed Tray reversing the paper position.
- Then perforate 2nd line again.

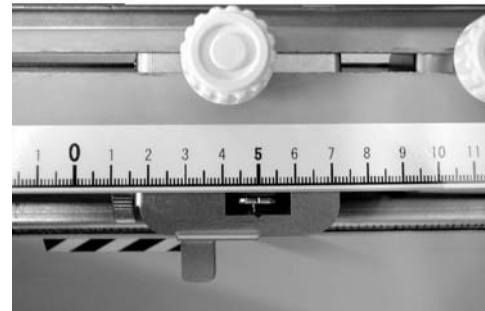
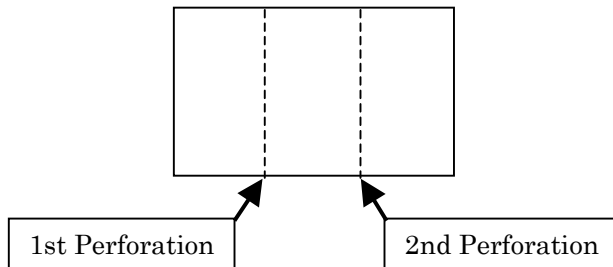

Further information:

If desired to perforate two lines by one operation, add one additional perforating block (optional) to the transport shaft.

Note due to frame size of perforating block, perforating too closed lines or too far apart lines may be limited.

Refer “ 4. Adding Perforation Unit “

NOTE:

Scale graduation and Blade Position Reference are for guidance only.

To perforate at the accurate position, use fine adjustment mechanism.

Refer “ 3.4.1 Adjusting line location ”

3.2 Method for changing operation mode

- (1) Press the “ Gear mark ” on the control panel to switch to the “ Setting ” screen.

Gear mark

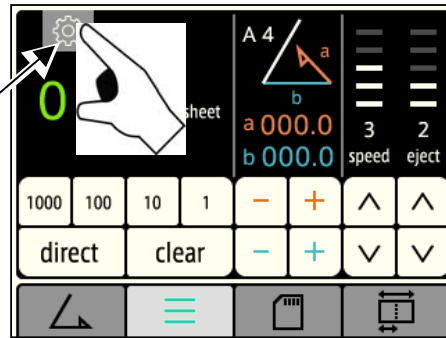

- (2) Press the “ Setting ” on the control panel to switch to the “ Detail Setting ” screen.

“ Back ” key

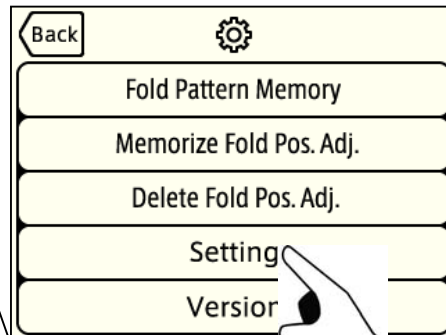

- (3) **To turn “ On ” the Perforator Mode.**

- By doing a long press (about 3 seconds) of the upper right of the display screen, it will change to the “ Perforator Mode ”.
- With this operation, the " Perfo. " will be displayed on the screen.
- Press the “ Back ” key to return to the “ Main Screen ”.
- Perforation / Scoring Unit(Optional) will be available..

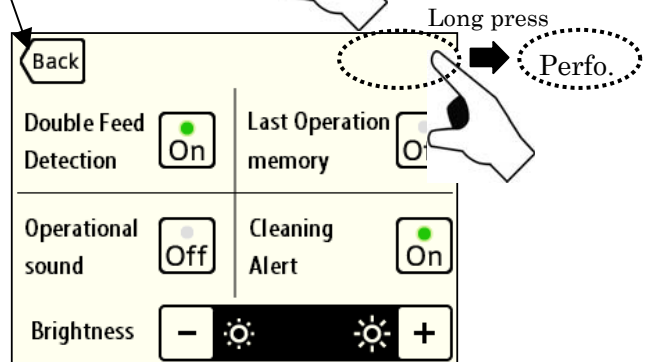

- (4) **To turn “ Off ” the Perforator Mode.**

- By doing a long press (about 3 seconds) of the "Perfo." was displayed on the upper right of the screen, it will exit the “ Perforator Mode ”.
- With this operation, the display of the "Perfo." will disappear from the screen.

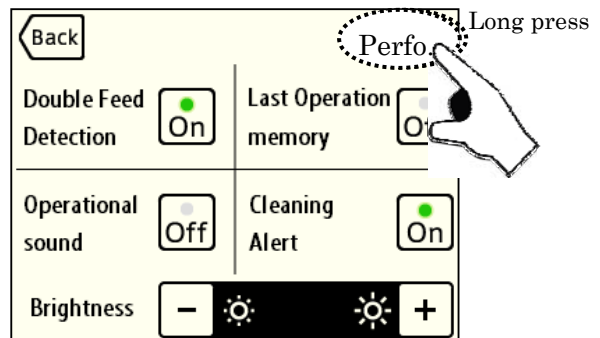

3.3 Trial Perforation

- (1) Turn on the power of Paper Folding Machine.
Switch to the “ Perforator Mode ”.
Refer to the “ 3.2 Method for changing operation mode ”.
- (2) Set papers on Paper Feed Tray, set Counter to “1” and press “START” Key.
- (3) Evaluate if the perforation is done properly as desired.

3.4 Fine Adjustment of Perforating Line

3.4.1 Adjusting line location

- If the line is extremely out of desired location, Perforating Unit must be relocated.
- If the line is away for approximately 5mm or less from desired position, fine adjustment may be possible without changing Perforating Block set up.

NOTE:

Before fixing Perforating Block, make sure to place Blade Position Reference to center position so that fine adjustment may be possible after the Block is fixed.

Fine Adjustment Dial:

While squeezing release levers, turn Fine Adjustment Dial to direction ① and Perforation position moves to right (direction ①).
When it is turned towards direction ②, Perforation position moves to left (direction ②).

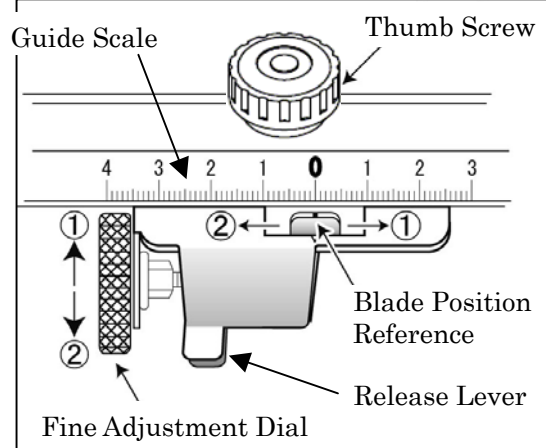

3.4.2 Adjustment of perforating angle

CAUTION !

Before making any adjustment, make sure that the paper is tightly placed without clearance between the Paper Guides in the Paper Feed Tray of Folder.
Otherwise, right angle of perforation is not available in any event.

In case perforation is not performed in the right angle, adjustment of angle may be possible.

【Refer to the figure on the right.】

- In case finishing of perforation is angled to right “a.”, turn Slant Adjustment Dial to the direction of “1”.
- In case finishing of perforation is angled to left “b.”, turn Slant Adjustment Dial to the direction of “2”.

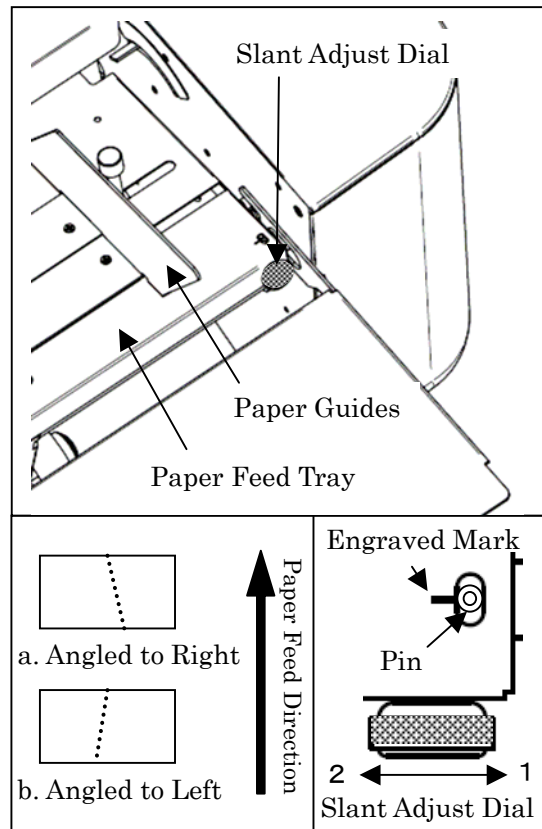

3.5 Perforation, continuous

- (1) Press “Reset/Clear” Key and clear the counter setting to “0 (Zero)”.
- (2) Perforate all the sheets loaded:
Load paper to Paper Feed Tray and press “START” Key.
Machine perforates up to the end of paper stack.
- (3) Perforate designated number of sheets:
Load paper to Paper Feed Tray and preset quantity of sheet desired to perforate.
Then, press “START”.
Machine perforates up to the designated quantity of sheet and stops.

3.6 Replacing Perforating Blade

- (1) While holding levers, loosen Thumb Screw and remove cutter unit from main unit.

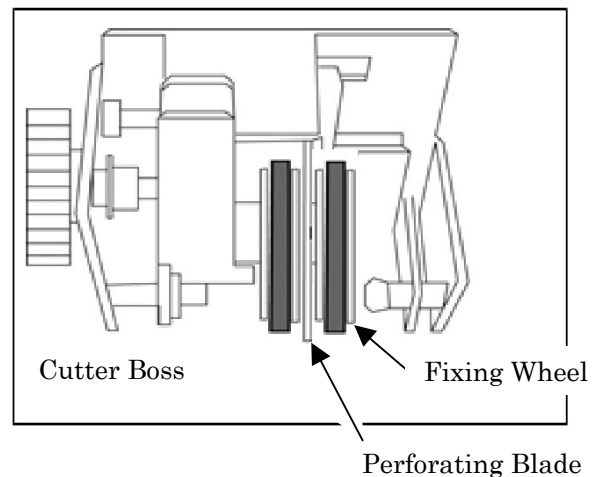
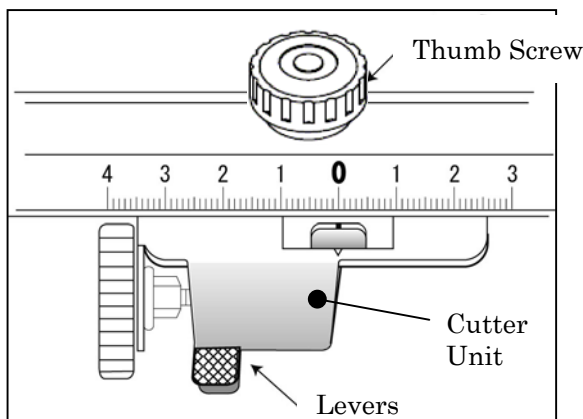

- (2) Remove 2 screws which are fixing Fixing Wheel by Philips screw driver and remove USED Perforating Blade.
First remove Fixing Wheel and then remove Perforating Blade.

CAUTION!

**Perforating Blade is extremely sharp.
Do not touch the blade.**

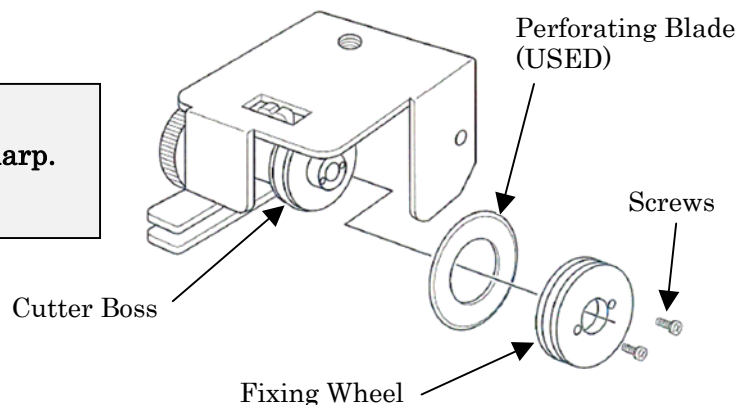

(3) Facing Explanation Level toward you per figure, Set NEW Blade to Cutter Boss.

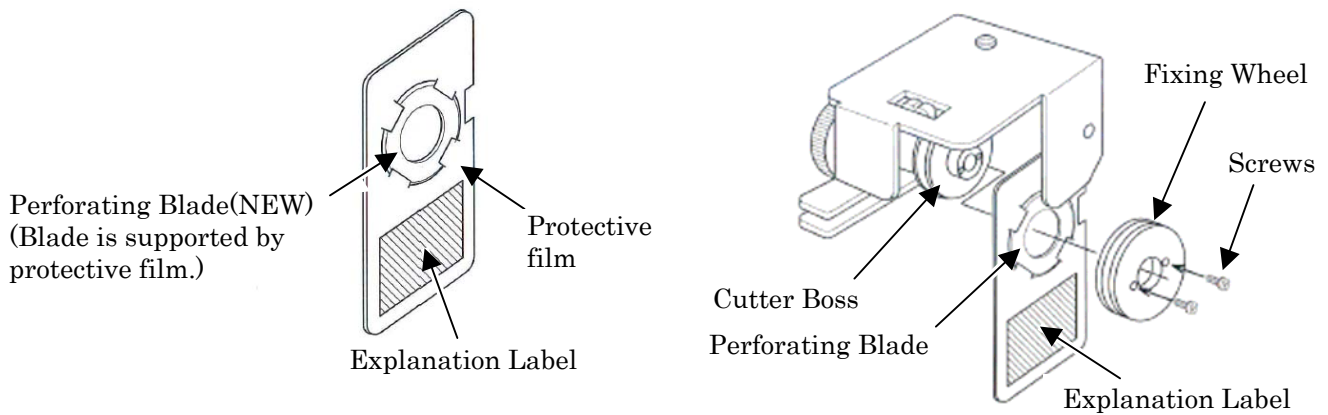

(4) Set Fixing Wheel by 2 Screws tight.

(5) Pull Protective Film toward direction of arrow so that the Film removes from the installed Blade.

※Film may be sometimes torn up but it is not a problem.

(6) Confirm that the two screws are firmly fixing the Fixing Wheel and consequently Blade.

(7) Mount the Cutter Unit to the machine in the reverse sequence of de-mounting.

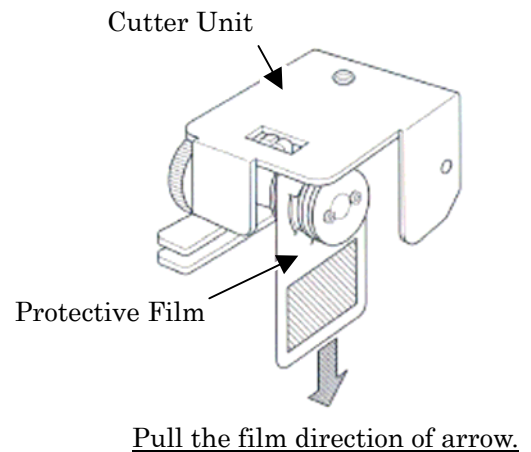

CAUTION !

1. 2 screws for fixing Fixing Wheel must firmly fixed.
2. Perforation Blade is extremely sharp and it must not be touched with bare finger.
3. After Perforation Blade (New) is firmly fixed to Cutter Unit, Protective Film must be pulled out.

How to use Thick-Paper Perforating Unit (Option)

1) How to install the Thick-paper Perforating Block (Optional Parts)

Loosen Thumb Screw and remove Standard Perforation Unit.

Replace with Thick-Paper Perforation Unit.
Then tighten the Thumb Screw to secure.

Thick-paper Perforating Block

Thumb Screw

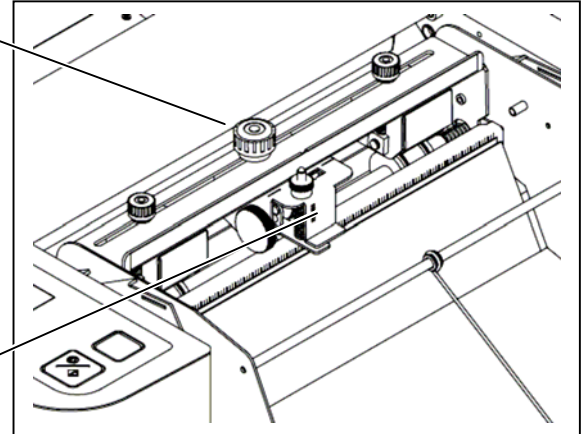

2) How to use

Pressure Control Nut

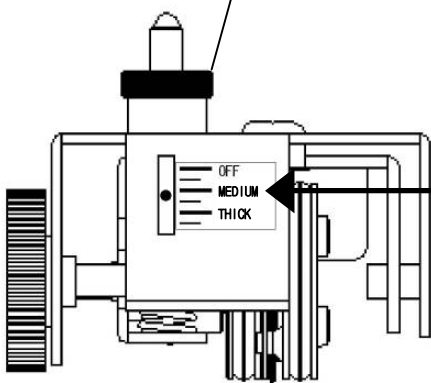

OFF : While keep installing Perforation Unit(Medium,Thick Paper or Narrow), Unit does not perforate paper.

MEDIUM : When medium thickness paper is perforated, adjust position here around, watching perforated sheet.

THICK : When thick paper is perforated, Adjust position here around, watching perforated sheet.

By rotating Pressure Control Nut, adjust Perforating blade pressure.

- When Thinner Paper
⇒ Rotate Clockwise (Pressure lowered)
- When Thicker Paper
⇒ Rotate Counter-Clockwise
(Pressure increased)

Pressure Control Nut

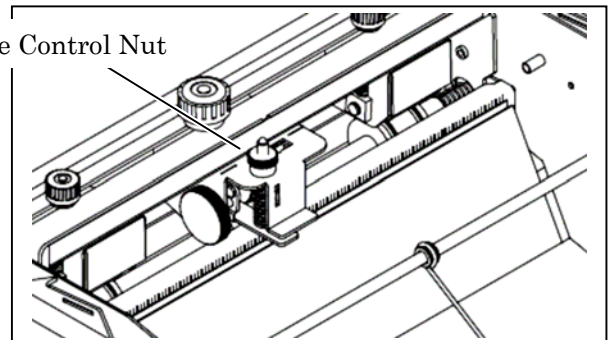

NOTE:

- 1) While watching how perforated, adjust pressure.
- 2) Perforating Blade is extremely sharp, do not touch by bare fingers.

※Other usage is the same as the Standard Perforation Unit.

Please refer to the “ 3. How to use “ and “ 4. Adding Perforation Unit “.

How to Replace the Separator with Thick-paper Separator

When fed, thicker paper might be damaged because of the friction between a paper feed roller and a separator.

You should change the separator with Thick-paper Separator in that case.

Thick-Paper Separator is marked with red-line.

Please refer to the following for how to replace the separator.

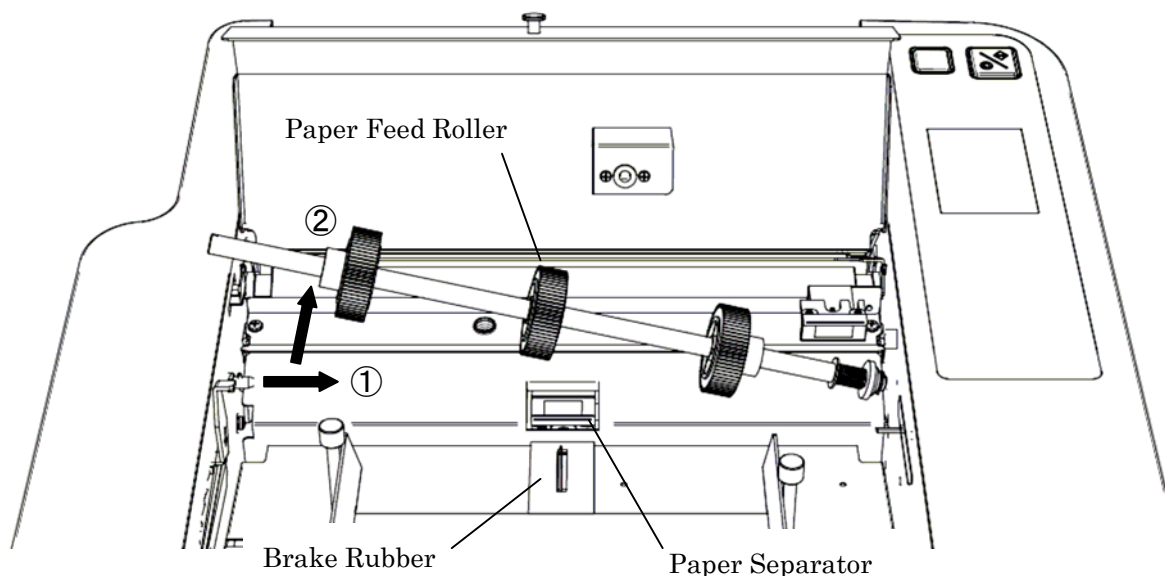

Raise the rear side to take out.

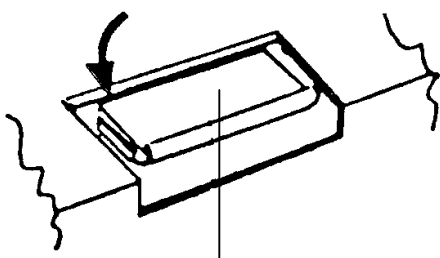

Paper Separator

How to remove a paper separator

② Press the rear side to set.

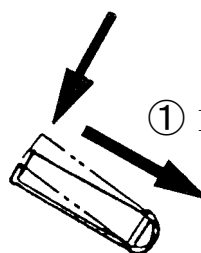

① Fit the front side in the curve.

How to place a paper separator

NOTE:

If paper still curves or other problem remains even when you operate the machine with Thick-paper separator, please turn over the papers you stack on the paper feed table and try again.

NOTE:

If you find the cut edge is not fine when you tear off along the perforation, fold the paper back and forth and tear it off slowly.

2) Scoring Unit

3.7 Setting Scoring Block

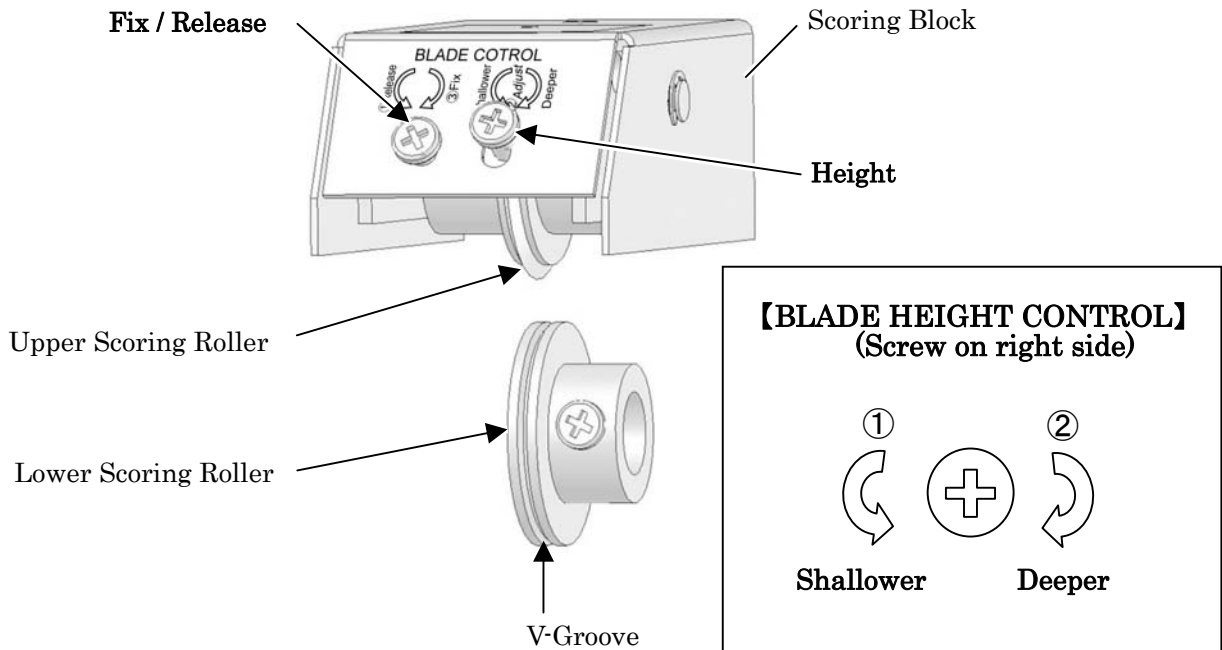

(1) Scoring Position

Move V-Groove of Lower Scoring Roller to the place where scoring.

Then, fix the Roller by Philips Screw Driver.

Press "Test" Key as leading edge of paper comes close to Lower Scoring Roller so that scoring position is determined.

Do not feed paper yet to the rollers.

(2) Positioning of Upper Scoring Roller

Loosen (turn) Release/Fix screw (left) on the left side for 2 to 3 rounds.

Turn Shallow/Deeper screw counterclockwise 2 to 3 rounds.

Slide the Upper Scoring Roller right above the lower V-Groove.

Turn Shallow/Deeper screw clockwise till Roller comes down in to the bottom of V-Groove.

Then, Fix the Scoring Block turning Release/Fix screw clockwise.

Now, Upper Blade and Lower Groove position is mechanically matched.

(3) Adjusting shallowness/depth of Upper Scoring Roller

Turn Shallower/Deeper screw counterclockwise for 2 to 3 turns. Then, fix the height by Fix/Release screw.

(4) Adjusting positions of Feed Rollers

Place Lower Transport Rollers to the positions where both of them stay on the paper positively. Then, fix Upper Transport Rollers by Phillips Screw Driver where Upper Rollers fit on the 2 Rubber Bands of Lower Transport Rollers.

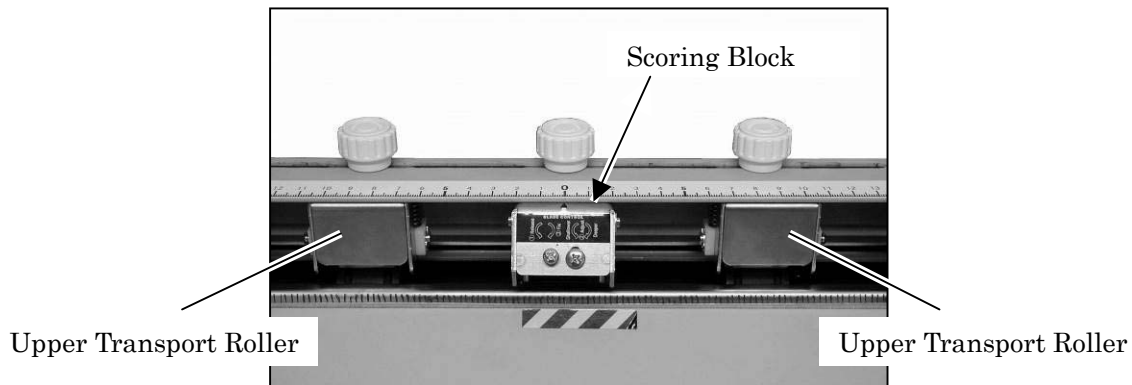

3.8 Trial Scoring

(1) Method of Trial Scoring, please refer to the “ 3.3 Trial Perforation”.

(2) Evaluate if the scoring is done properly as desired.

Please refer to the ” 3.9 Fine Adjustment of Scoring Line “ if adjustment is needed.

3.9 Fine Adjustment of Scoring Line

3.9.1 Shallower/Deeper Fine Adjustment

By turning Shallower/Deeper Screw, scoring depth is adjustable.

Loosen Release/Fix Screw first and make shallower/deeper adjustment.

After adjustment, fix it by Release/Fix Screw.

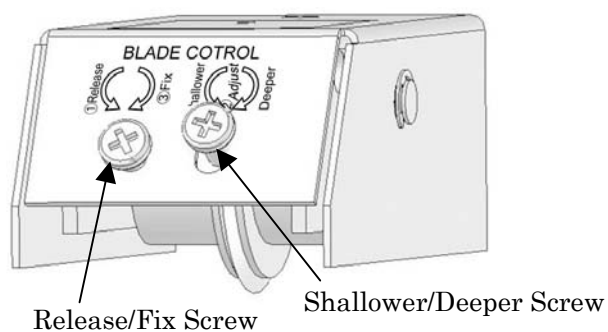

【BLADE HEIGHT CONTROL】
(Screw on right side)

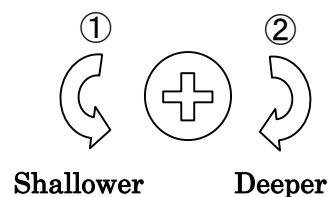

3.9.2 Adjusting scoring line location

Slide and move Lower Scoring Roller first, then slide Upper Scoring Roller.

Make sure to fix both Rollers by Phillips Screw Driver after moved.

3.9.3 Adjusting scoring Angle

In case scoring is not made in square, refer “3.4.2 Adjustment of perforating angle”.

3.10 Scoring, continuous

- (1) Press “Reset/Clear” key and clear the counter setting to “0 (Zero)”.

- (2) Scoring all the sheets loaded:
Load paper to Paper Feed Tray and press “START” Key.
Machine scores up to the end of paper stack.

- (3) Scoring designated number of sheets:
Load paper to Paper Feed Tray and preset quantity of sheet desired to scores.
Then, press “START” .
Machine scores up to the designated quantity of sheets and stops.

4. Adding Perforation Unit

(1) Remove Transportation Shaft from Perforation Unit

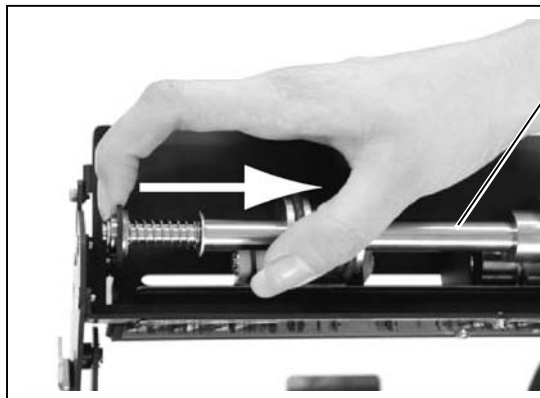

Transportation Shaft

Block Mounting Arm

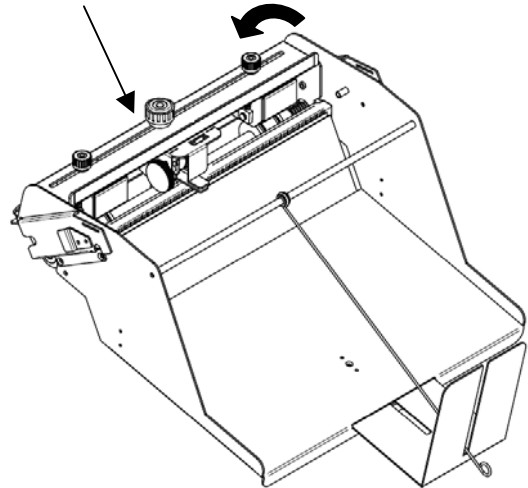

NOTE:

When removing Transportation Shaft, rotate Block Mounting Arm toward the direction of arrow. It makes wider opening and easier to take out Transportation Shaft.

(2) Remove a Phillips screw from the end of Transportation Shaft.

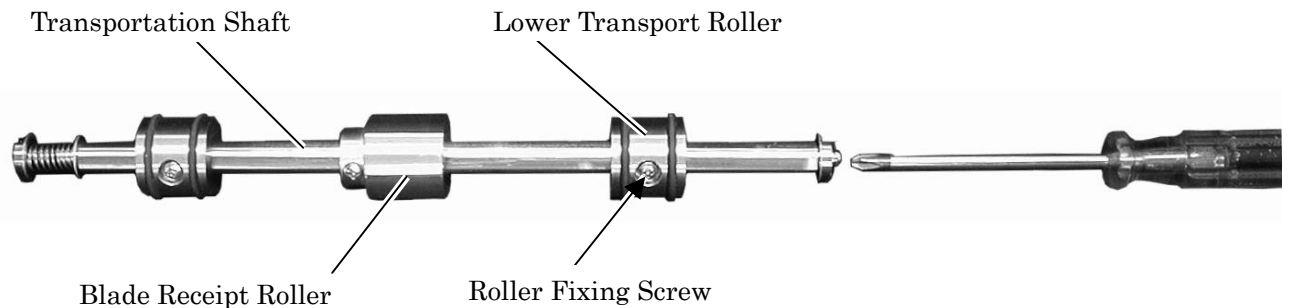

(3) Remove Lower Transport Roller from the Shaft after loosening Roller Fixing Screw.

(4) Add another Blade Receipt Roller to the Shaft and re-mount Lower Transport Roller.

Then, fix Rollers by screws.

Fix the Phillips Screw at end of the Shaft.

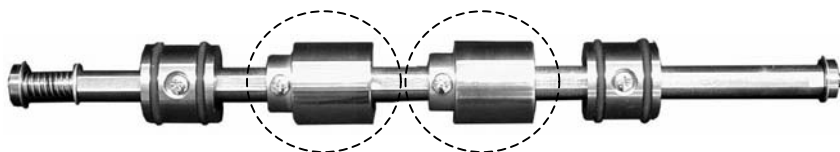

《Seen as two Perforation Units are mounted.》

- (5) Add another Perforation Unit to the Block Mounting Arm and fix by Thumb Screw.
- (6) Place Transportation Rollers where they grip perforating sheet positively.
The two Perforation Units should not touch each other.

NOTE:

Position where perforation can be done is only between the two Lower Transportation Rollers.

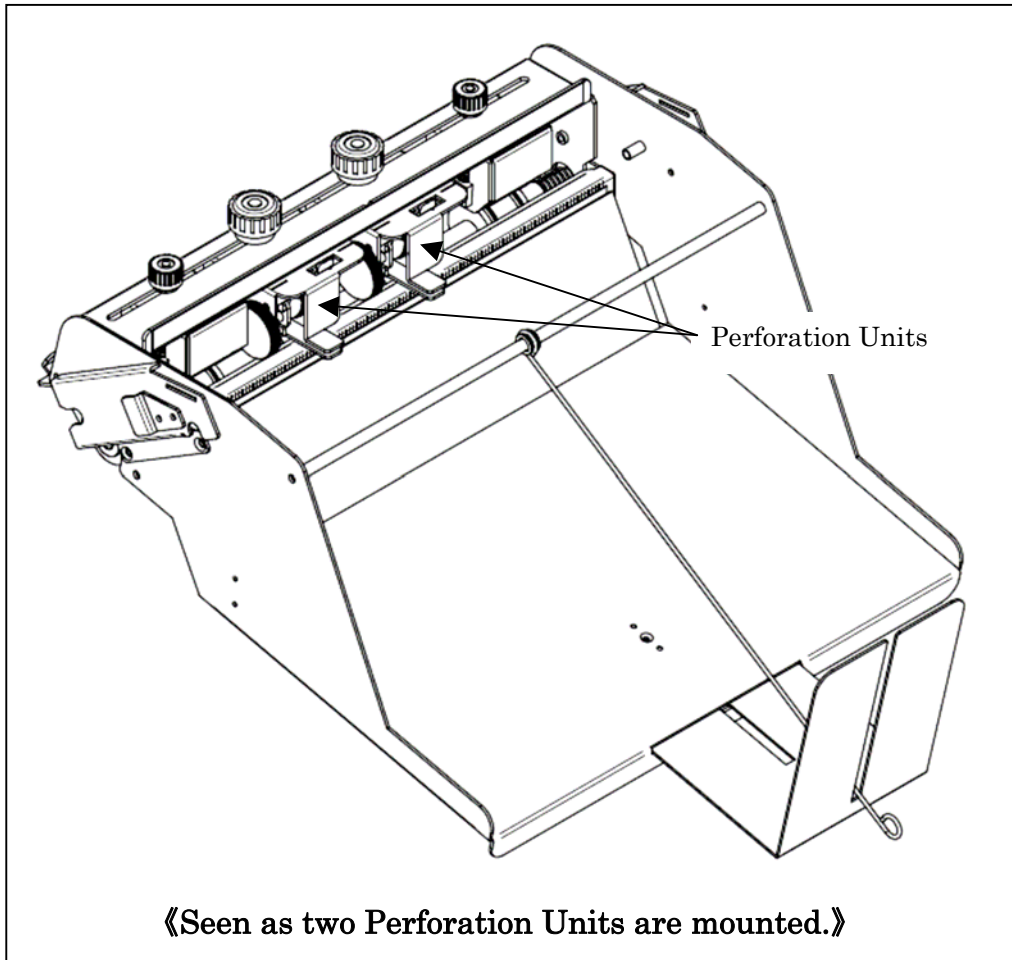

5. Exchanging Perforation Unit to Scoring Unit.

Perforation Unit can be exchanged to Scoring Unit and Scoring Unit can be exchanged to Perforating Unit.

- (1) Remove Transportation Shaft from Perforation Unit

NOTE:

For easier removal or installation,
Refer “ NOTE: ” at “ 4. Adding
Perforation Unit “ .

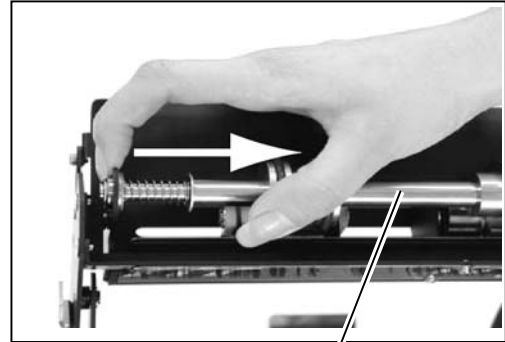

Transportation Shaft

- (2) Remove a Phillips screw from the end of Transportation Shaft.

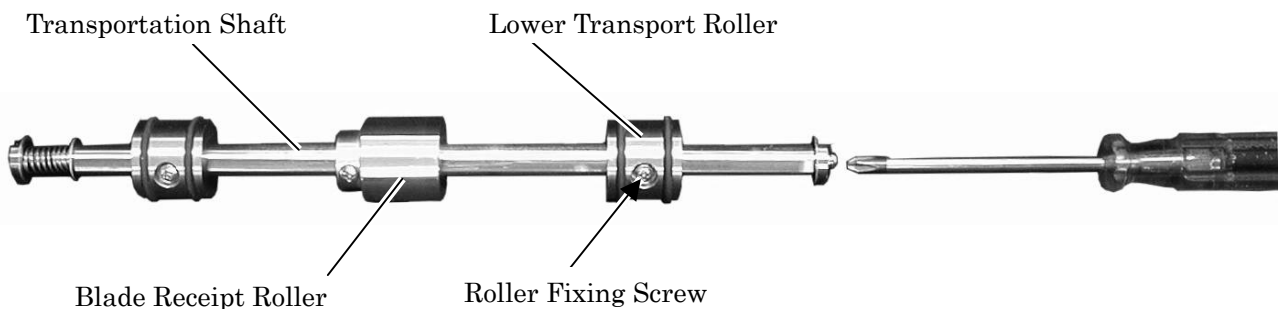

- (3) Remove Lower Transportation Roller from the Shaft after loosening Lower Fixing Screw.

- (4) Replace with Lower Transportation Roller, Blade Receipt Roller, etc. Fix the Phillips screw at end of the Shaft.

- (5) Mount Lower Transportation Roller and fix it. Then, re-mount Transportation Shaft to the Perforation Unit.

- (6) Place Scoring Block or Perforating Block as desired.

- (7) Refer “ 3. How to use ” for use of Scoring and Perforating work.

6. Replacing Transport Rubber Ring

- (1) Remove Transportation Shaft from Perforation/Scoring Unit

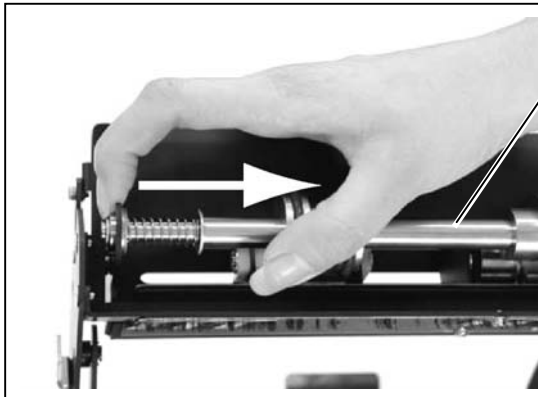

Transportation Shaft

NOTE:

For easier removal or installation,
Refer "NOTE: " at "4. Adding
Perforation Unit " .

- (2) Remove a Phillips screw from the end of Transportation Shaft.

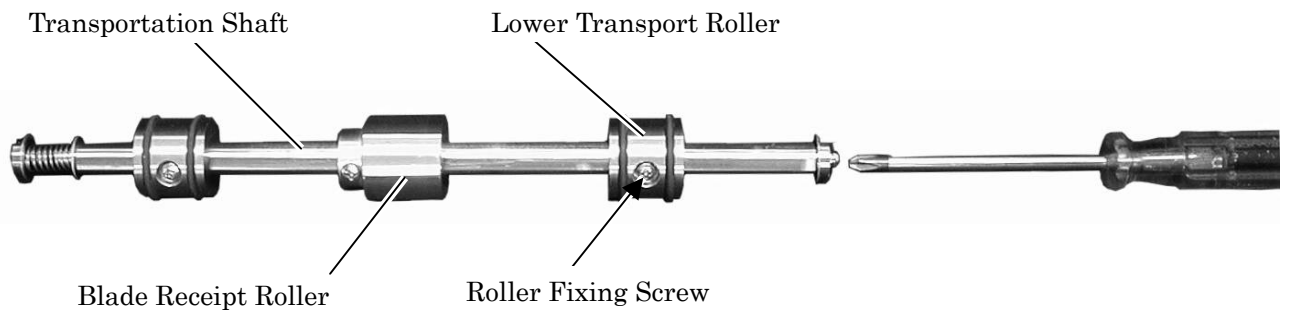

- (3) Remove Lower Transport Roller from the Shaft after loosening Roller Fixing Screw.

- (4) Remove used/old Rubber Ring from the Lower Transport Roller.

Please be careful not to damage the roller when you cut the rubber ring.

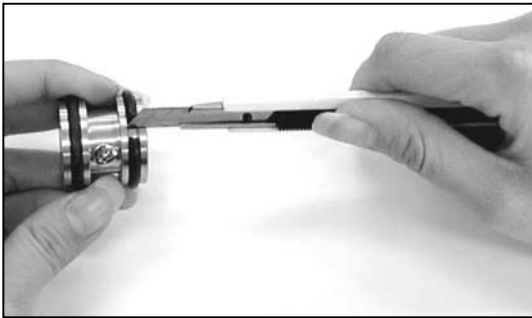

- (5) Mount new Rubber Ring

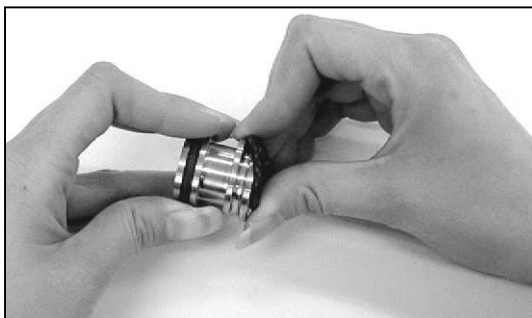

- (6) Re-mount Lower Transport Roller in the reversed procedures.

7. Troubleshooting

Symptom	Remedy
Paper Slippage	- Replace Paper Separator - Replace Paper Feed Roller
Paper Jam	- Remove jammed paper by removing Perforation/Scoring Unit from Folding Machine. - Remove jammed paper. Then adjust mounting location of Roller. Make the Transport Rollers grip perforating/scoring paper at the both sides. - Slow down running speed
Slanting	- Make no play to the paper placed between the Paper Guides in the Paper Feed Tray of the Folding Machine. - Adjust by Slant Adjustment Dial. - Adjust mounting location of Transport Roller. Make the Transport Rollers grip perforating/scoring paper at the both sides. - Re-mount Perforating/Scoring Unit firmly to Block Mounting Arm.
Not Sufficient Perforation	- Make sure to ride Perforating Blade on Blade Receipt Roller. - Replace used/old Framed Perforating Blade to new one.
Torn Scoring	- Upper Scoring Roller is too deep. Lift the Scoring Roller by Shallower/Deeper Adjustment Screw. - Upper Scoring Roller is not matching with V-Grooved Lower Scoring Roller. Match the Upper Scoring Roller to V-Groove by Fine Adjustment Dial.
Not Sufficient Scoring	- Upper Scoring Roller is too shallow against V-Grooved Lower Scoring Roller. Lower the Scoring Roller by Height Adjustment Screw.

8. Product Specifications

Paper Weight	Perforation: 64~127.9 g/m ²	17~35 lbs (Bond)
	Scoring : 64~157 g/m ²	17~42 lbs (Bond)
Paper Quality	Offset paper / Coated paper	Offset paper / Coated paper
Running speed	60 to 85 sheets/minute (3600 to 5100 sheets/hour)	A4 landscape
Location of perforation and scoring line	Centering	In case A4 paper, landscape, + or - 50mm (1.96") when Transportation Rollers are placed at paper sides
Perforating pitch	0.35mm(perforation), 0.20mm(non-perforation), continuous	0.014"(perforation), 0.008"(non-perforation), continuous
Machine Dimensions (Both Perforation and Scoring Units)	In Use: W480 x D380 x H200 mm Not InUse: W380 x D380 x H200 mm	In Use: W18.9 x D15.0 x H7.9" Not In Use: W15.0 x D15.0 x H7.9"
Unit Weight (Both Perforation and Scoring Units)	Approx. 4.8 kg	Approx. 10.6 lbs

MBM Corporation